



**CITY OF ALBERTVILLE
STANDARD CONSTRUCTION DETAILS**

SEPTEMBER 2021

**ALBERTVILLE PUBLIC WORKS
11822 63RD STREET NE
ALBERTVILLE, MN 55301**

TYPICAL SECTIONS

<u>Plate #</u>	<u>Subject</u>
ALBT_1-001	Typical Street Section Residential
ALBT_1-004	Bituminous Trail
ALBT_1-100	Bituminous Patch
ALBT_1-101	Concrete Driveway Pavement
ALBT_1-102	Crack Sealing Typical Section
ALBT_1-300	Minimum Street Standards
ALBT_1-400	Temporary Bituminous Cul-De-Sac
ALBT_1-600	Bituminous Driveway
ALBT_1-700	Concrete Walk

EROSION CONTROL

<u>Plate #</u>	<u>Subject</u>
ALBT_3-001	Ditch Check - Rip Rap
ALBT_3-002	Ditch Check - Bioroll
ALBT_3-004	Velocity Check - Heavy Duty Silt Fence
ALBT_3-101	Inlet Protection - Perforated Wall
ALBT_3-102	Inlet Protection - Road Drain Curb and Gutter
ALBT_3-200	Erosion Control Blanket Installation
ALBT_3-201	Erosion Control Blanket at Pond EOF
ALBT_3-202	Skimmer Weir (Pond or Wide Channel)
ALBT_3-203	Skimmer Weir (Narrow Channel)
ALBT_3-204	Silt Fence - Heavy Duty
ALBT_3-205	Silt Fence - Preassembled
ALBT_3-206	Silt Fence - Machine Sliced
ALBT_3-207	Silt Fence - Super Heavy Duty
ALBT_3-404	Silt Fence - Floatation Silt Curtain
ALBT_3-405	Silt Fence - Floatation Silt Curtain (Still Water)
ALBT_3-500	Typical Sediment Basin Cross Section
ALBT_3-502	Rock Construction Entrance
ALBT_3-600	Riprap at RCP Culvert End
ALBT_3-700	Construction Site Erosion Control

STORM SEWER

<u>Plate #</u>	<u>Subject</u>
ALBT_4-001	RC Pipe Class "B" Bedding
ALBT_4-002	PVC Storm Sewer Trench Detail
ALBT_4-101	Catch Basin - Design "H"
ALBT_4-105	Storm Sewer Structure - Design 4020
ALBT_4-107	Precast Shallow Depth MH/CB - Design SD
ALBT_4-108	Drainage Structure with Sump
ALBT_4-200	Precast Concrete Pond Skimmer Structure
ALBT_4-201	Precast Concrete Pond Skimmer Structure W/Rate Control Baffle
ALBT_4-303	Subsurface Edge Drain PVC Pipe
ALBT_4-304	Subsurface Edge Cleanout under Sidewalk
ALBT_4-305	Subsurface Edge Cleanout
ALBT_4-306	Sump Pump Discharge Requirements (2 Sheets)
ALBT_4-307	Precast Concrete Headwall for Subsurface Drains
ALBT_4-601	RC Apron Trash Rack
ALBT_4-800	Pond Detail



TABLE
OF CONTENTS
(PAGE 1 OF 3)



DATE:
02/2020

STD. DETAIL
ALBT_TAB1

SANITARY SEWER

<u>Plate #</u>	<u>Subject</u>
ALBT_5-000	Sanitary Manhole
ALBT_5-002	Sanitary Manhole with Outside Drop
ALBT_5-008	Sanitary Sewer Exterior Joint Seal
ALBT_5-019	Casting and Grading Adjustment Ring Detail
ALBT_5-020	Casting and Grade Adjustment Ring Exterior Seal
ALBT_5-101	Sanitary Sewer Service
ALBT_5-104	Sanitary Sewer Riser
ALBT_5-107	Sanitary Sewer Service and Service Riser – Reconstruction
ALBT_5-110	Sanitary Sewer Cleanout
ALBT_5-200	PVC Sanitary Sewer Trench
ALBT_5-202	Insulation Sanitary Sewer

WATERMAIN

<u>Plate #</u>	<u>Subject</u>
ALBT_6-000	Hydrant
ALBT_6-101A	Water Service Installation
ALBT_6-200	PVC Watermain Trench
ALBT_6-201	DIP Watermain Trench
ALBT_6-202	Watermain Insulation
ALBT_6-203	Watermain Offset
ALBT_6-204	Watermain Pipe Support in Casing – Plastic Spacers
ALBT_6-205	Concrete Thrust Blocks
ALBT_6-206	Concrete Thrust Blocking
ALBT_6-301	Tracer Wire Pedestal PVC Pipe
ALBT_6-302	Tracer Wire Pedestal Valve Box
ALBT_6-303	Adjustable Tracer Wire Access Box
ALBT_6-304	Tracer Wire Access at Hydrant
ALBT_6-400	Gate Valve Adaptor
ALBT_6-402	Gate Valve Installation

CURB & GUTTER, SIDEWALKS AND RETAINING WALLS

<u>Plate #</u>	<u>Subject</u>
ALBT_7-000	Concrete Curb & Gutter
ALBT_7-001	Transition to B618 Curb at Catch Basin
ALBT_7-002	Concrete Curb Reinforcement
ALBT_7-100	Concrete Valley Gutter
ALBT_7-101	Concrete Drainage Pan
ALBT_7-102	Commercial Concrete Driveway Apron
ALBT_7-201	Ped Ramp with Truncated Domes in Curb Radius
ALBT_7-202	Ped Ramp with Truncated Domes in Straight Curb Sections
ALBT_7-204	Concrete Steps



TABLE
OF CONTENTS
(PAGE 2 OF 3)



DATE:
02/2020

STD. DETAIL
ALBT_TAB2

SIGNS, TRAFFIC SIGNALS AND MARKERS

<u>Plate #</u>	<u>Subject</u>
ALBT_8-100	Traffic Sign Installation
ALBT_8-101	Street Name Blade Installation w/Traffic Sign
ALBT_8-102	Sign Post Break-Away Assembly
ALBT_8-110	Manhole Marker Sign
ALBT_8-111	Structure Marker Signs
ALBT_8-114	Street Name Sign
ALBT_8-115	Street Sign Post Installation
ALBT_8-116	Street Signs
ALBT_8-118	Wetland Buffer Zone Sign Installation

MISCELLANEOUS

<u>Plate #</u>	<u>Subject</u>
ALBT_9-003	Tree Preservation Fence
ALBT_9-300	Bollard Guard Post
ALBT_9-301	Mailbox Installation Detail
ALBT_9-600	Sewer & Water Service Record Drawing



TYPICAL STREET SECTION RESIDENTIAL

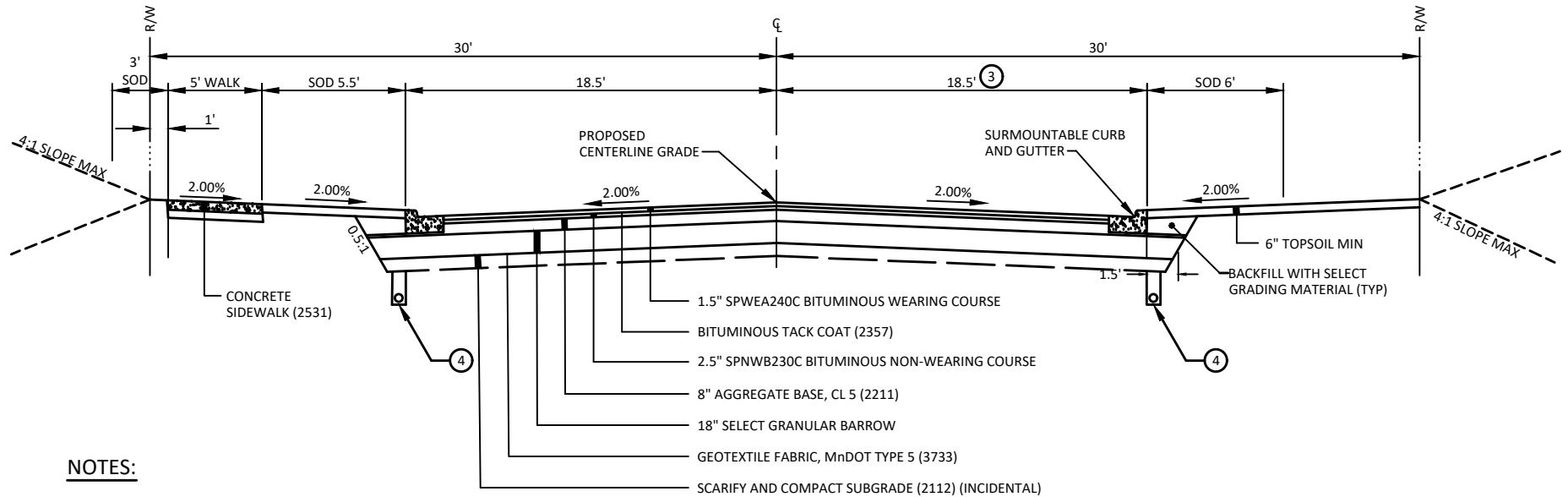

NOTES:

- ① SEE STANDARD DETAIL 1-300 FOR STREET CLASSIFICATION MINIMUM ROADWAY SECTIONS.
- ② THE PAVEMENT SECTION SHOWN IS A MINIMUM. TYPE OF BITUMINOUS MIXTURE AND THE SECTION MAY BE INCREASED BY THE CITY ENGINEER BASED ON A SOILS REPORT AND PROJECTED TRAFFIC VOLUMES.
- ③ STREET WIDTH TO BE DETERMINED BY THE CITY ENGINEER. STREETS MUST BE PAVED IN NO MORE THEN TWO PASSES.
- ④ 4" PERFORATED PIPE. INSTALL WHERE CLAY SOILS ARE ENCOUNTERED IN THE ROADWAY SUBGRADE AS DIRECTED BY THE CITY ENGINEER.



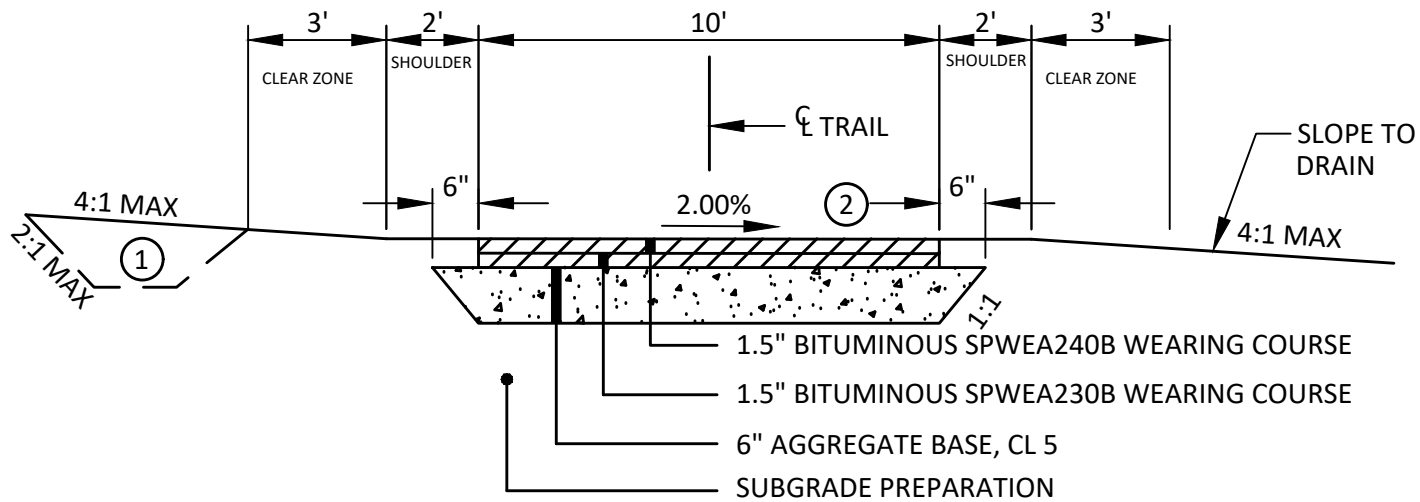

- ① DITCH IF REQUIRED FOR DRAINAGE
- ② SLOPE TOWARDS INSIDE OF CURVE

BITUMINOUS TRAIL

NOT TO SCALE

NOTE:

PROVIDE 10' MINIMUM RADIUS AT ALL TRAIL INTERSECTIONS.

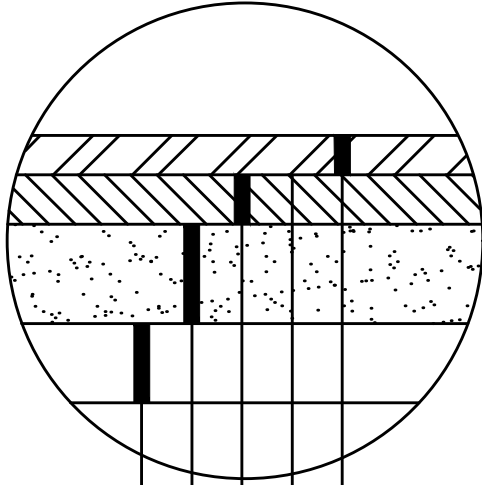

- 1.5" SPWEA240B BITUMINOUS WEARING COURSE
- BITUMINOUS TACK COAT (2357)
- 2.5" SPNWB230B BITUMINOUS NON-WEARING COURSE
- 8" AGGREGATE BASE, CL 5 (2211)
- SUBGRADE PREPARATION (2112) (INCIDENTAL)

BITUMINOUS PATCH
NOT TO SCALE

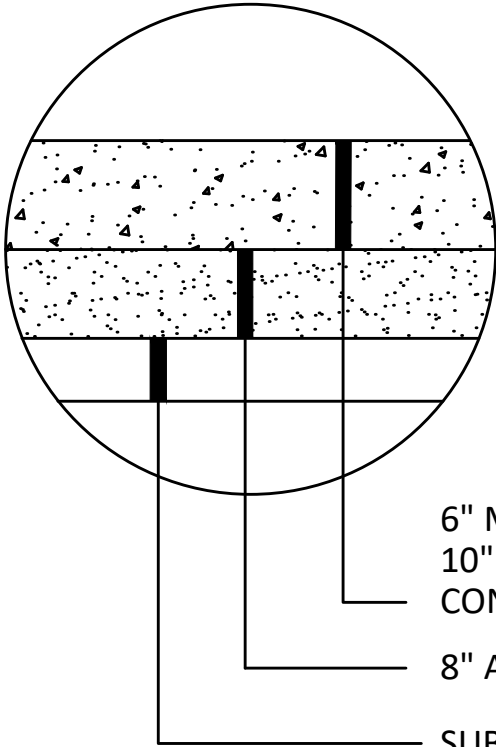

6" MIN. FOR RESIDENTIAL CONC. DWY/APRON
 10" MIN. FOR COMMERCIAL CONC. DWY/APRON
 CONCRETE DRIVEWAY PAVEMENT (2531)

8" AGGREGATE BASE, CL 5 (2211)

SUBGRADE PREPARATION (2112)

CONCRETE DRIVEWAY PAVEMENT

NOT TO SCALE

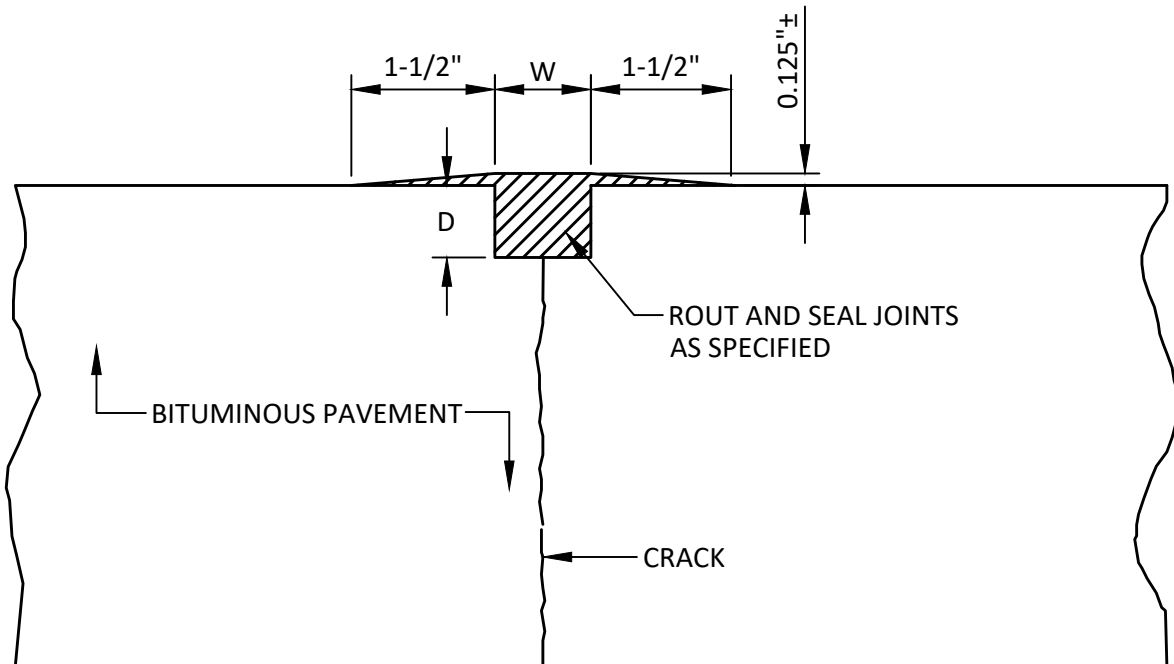

<u>W</u>	<u>D</u>
1"	0.75"
2"	1.25"

CRACK SEALING TYPICAL SECTION
NOT TO SCALE

FUNCTIONAL CLASSIFICATION	B-B WIDTH (FT)	ROW WIDTH	MINIMUM ROADWAY SECTION
COMMERCIAL / INDUSTRIAL	45'	80'	2" SPWEA340C 3" SPNWB330C 10" CLASS 5 AGGREGATE BASE 18.0" SELECT GRANULAR GEOTEXTILE FABRIC
LOCAL	37'	60'	1.5" SPWEA240C 2.5" SPNWB230C 8" CLASS 5 AGGREGATE BASE 18.0" SELECT GRANULAR GEOTEXTILE FABRIC
LOCAL (WITH SIDEWALK IN ROW)	35'	60'	1.5" SPWEA240C 2.5" SPNWB230C 8" CLASS 5 AGGREGATE BASE 18.0" SELECT GRANULAR GEOTEXTILE FABRIC
MINOR COLLECTOR	37'-45'	66'-80'	2" SPWEA340C 3" SPNWB330C 10" CLASS 5 AGGREGATE BASE 18.0" SELECT GRANULAR GEOTEXTILE FABRIC
COLLECTOR	45'	80'	AS DETERMINED BY TRAFFIC NEEDS
ARTERIAL	VARIES	100'+	AS DETERMINED BY TRAFFIC NEEDS



MINIMUM STREET STANDARDS



DATE:
03/2021

STD. DETAIL
1-300

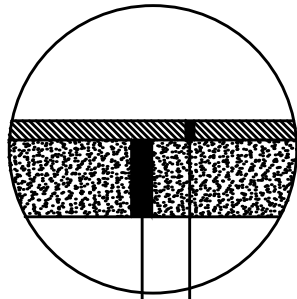

2.5" SPWEA240B

8" CL. 5 AGGREGATE BASE, CL. 5 (2211)

TEMPORARY BITUMINOUS CUL-DE-SAC
PAVEMENT SECTION

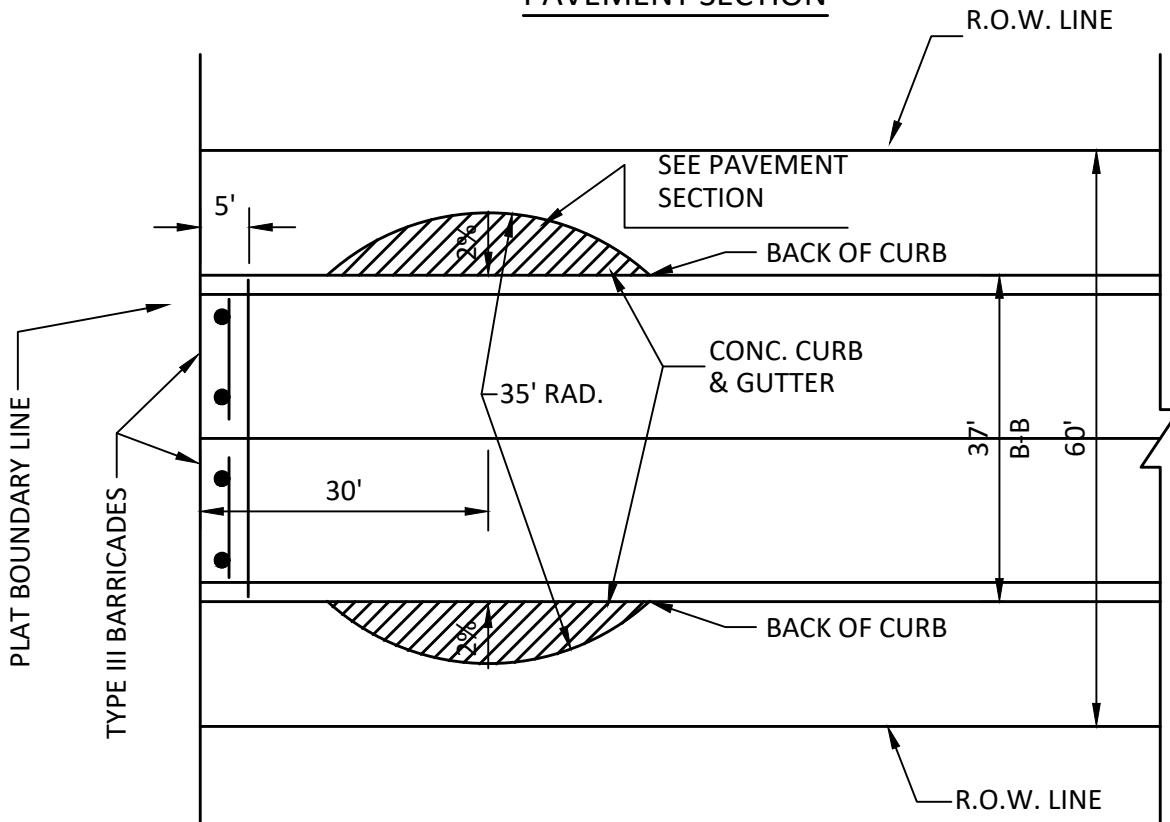

TEMPORARY BITUMINOUS CUL-DE-SAC
PLAN VIEW

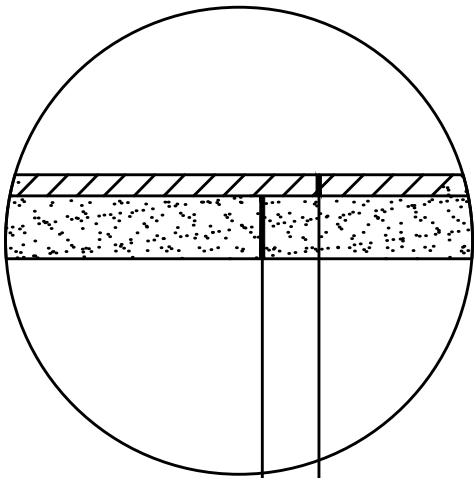

3" SPWEA240B BITUMINOUS WEARING COURSE
 6" AGGREGATE BASE, CLASS 5 (SPEC 2221)

BITUMINOUS DRIVEWAY
 NOT TO SCALE

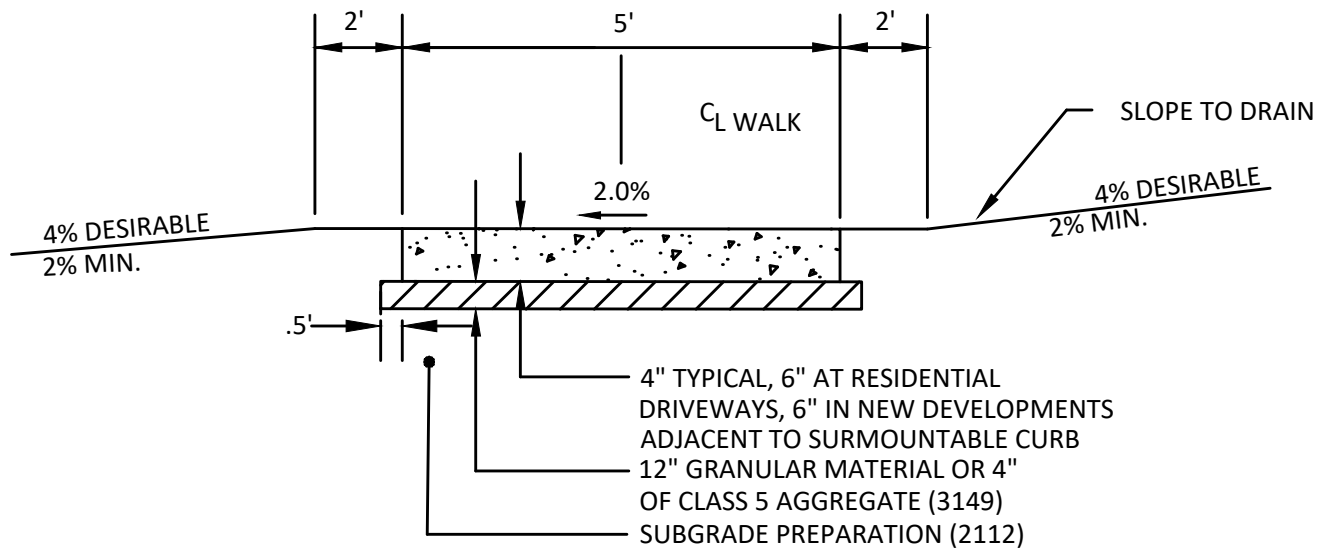

NOTE:

CONCRETE MIX SHALL BE 3A32 WHERE HAND PLACED AND 3A22 WHERE MACHINED PLACED.

GRANULAR BASE SHALL BE SELECT GRANUAL (MNDOT 3149-B2).

WITHIN ONE HOUR AFTER THE CONCRETE IS FINISHED, ALL EXPOSED SURFACES; FRONT, TOP, AND BACK, SHALL BE SPRAYED WITH MEMBRANE CURING COMPOUND CONFORMING TO MNDOT 3754 AT A RATE OF NOT LESS THAN 1 GALLON PER 150 SF.

EXPANSION JOINT SPACING SHALL BE 100'. (MAX)
CONTRACTION JOINT SPACING SHALL BE 5'. (APPOX)

AT COMMERCIAL ENTRANCE AND DWY CROSSINGS, SECTION SHALL BE MODIFIED TO 7" CONCRETE AND 6" CLASS 5 AGG.

CONCRETE WALK

NOT TO SCALE



CONCRETE
WALK



DATE:
02/2020

STD. DETAIL
1-700

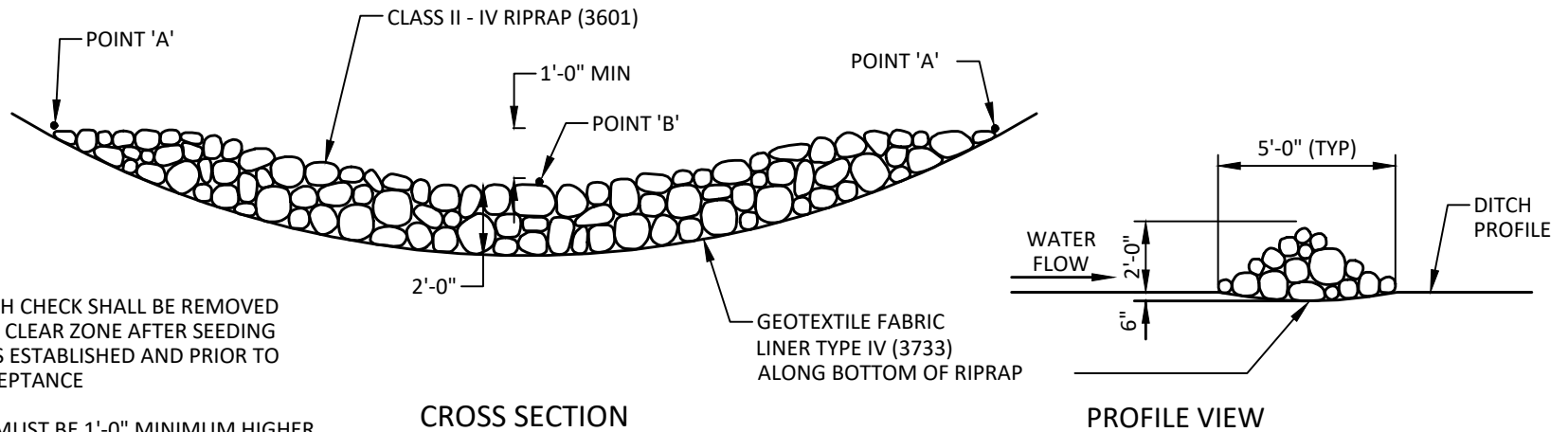

NOTE:
 ROCK DITCH CHECK SHALL BE REMOVED FROM THE CLEAR ZONE AFTER SEEDING OR TURF IS ESTABLISHED AND PRIOR TO FINAL ACCEPTANCE

POINT 'A' MUST BE 1'-0" MINIMUM HIGHER THAN POINT 'B' TO ENSURE THAT WATER FLOWS OVER THE DIKE AND NOT AROUND THE ENDS.

CROSS SECTION

PROFILE VIEW

DITCH CHECK - RIPRAP
 NOT TO SCALE

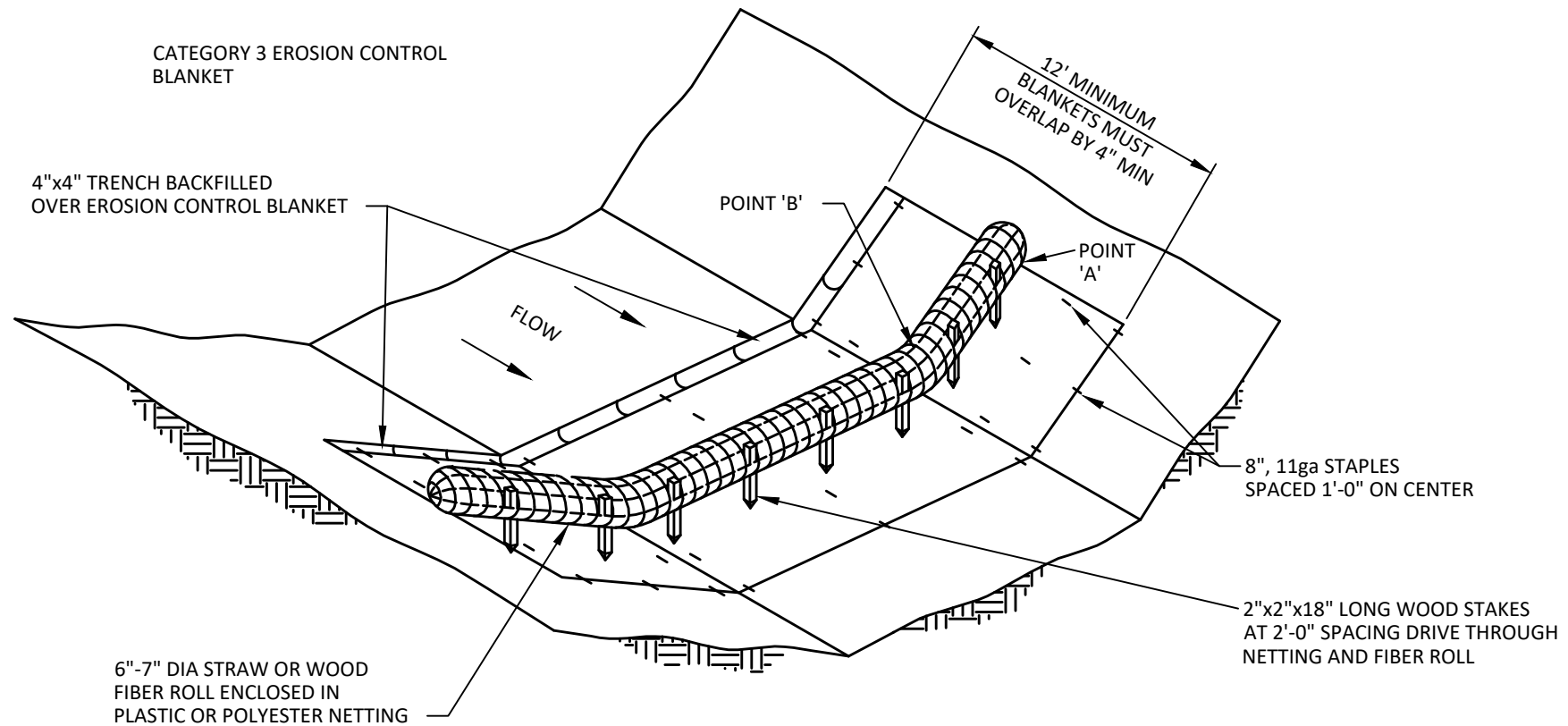

DITCH CHECK - BIOROLL
NOT TO SCALE

NOTE:
POINT 'A' MUST BE 1'-0" MINIMUM HIGHER THAN POINT 'B' TO ENSURE THAT WATER FLOWS OVER THE DIKE AND NOT AROUND THE ENDS.

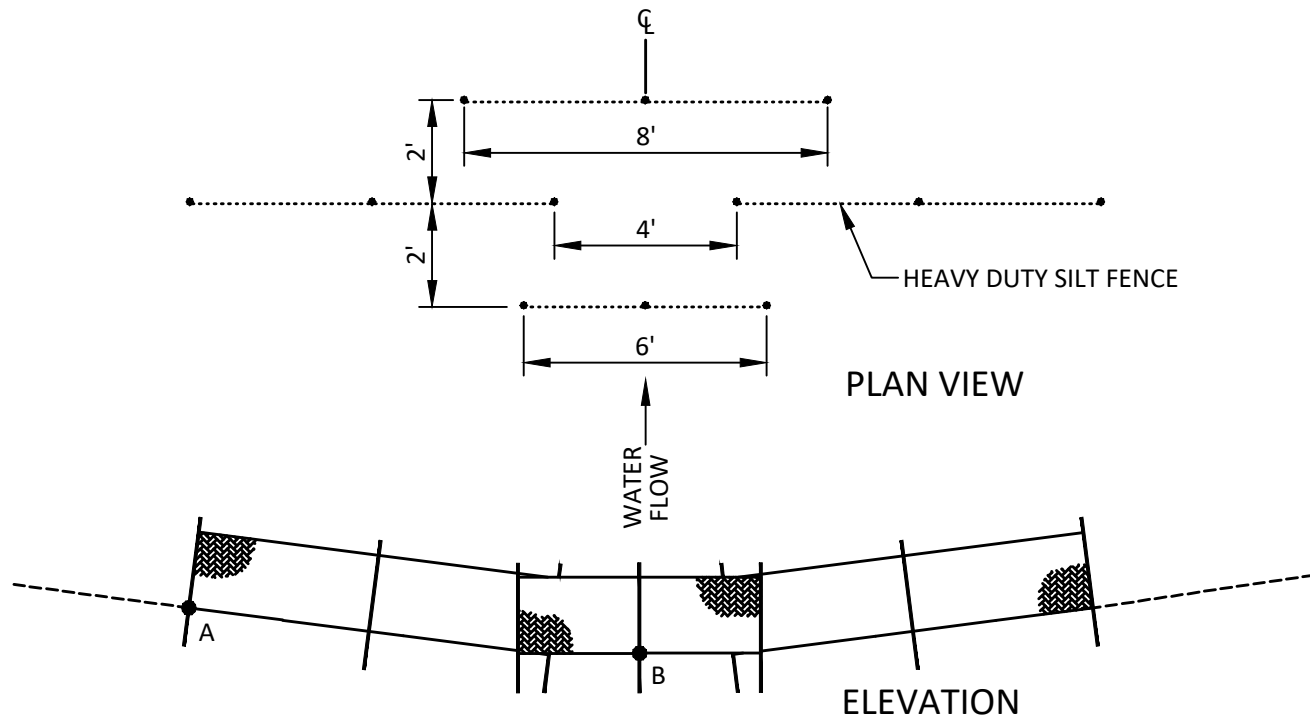

NOTES:

1. POINT A MUST BE A MINIMUM OF 12 INCHES HIGHER THAN POINT B.
2. HEAVY DUTY SILT FENCE SHALL CONFORM TO THE REQUIREMENTS OF MnDOT SPECIFICATION 3886.
3. DIMENSIONS SHOWN ARE FOR TYPICAL 8' DITCH BOTTOM. MODIFICATIONS MAY BE NECESSARY FOR VARYING SLOPES AND DITCH WIDTHS.
4. REFER TO PLAN OR MnDOT EROSION CONTROL MANUAL FOR SPACING INTERVALS OF CHECKS.

**VELOCITY CHECK
HEAVY DUTY SILT FENCE**

NOT TO SCALE



VELOCITY CHECK
HEAVY DUTY SILT FENCE



DATE:
02/2020

STD. DETAIL
3-004

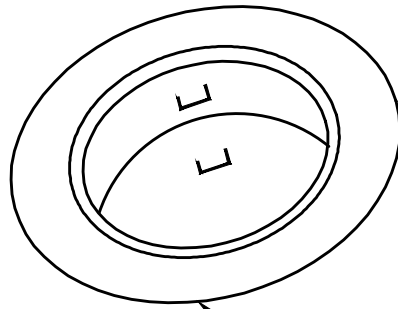

PLACE BARRIER FRAME ATOP
PRE-CAST TOP SLAB

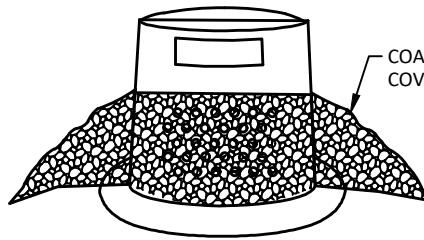

COARSE FILTER AGGREGATE PLACED TO
COVER PERFORATIONS

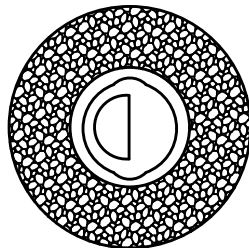

COARSE FILTER AGGREGATE PLACED TO
COVER PERFORATIONS

TOP VIEW

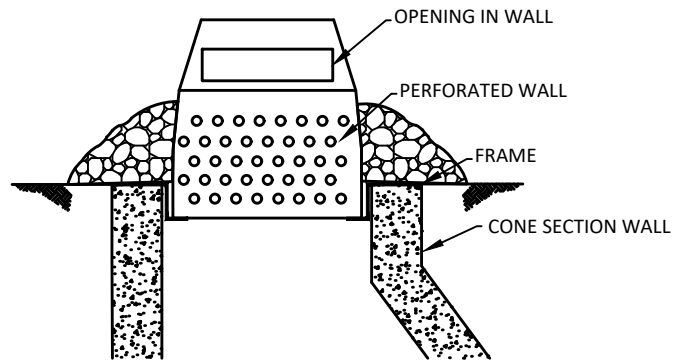

OPENING IN WALL

PERFORATED WALL

FRAME

CONE SECTION WALL

INLET PROTECTION
PERFORATED WALL

NOT TO SCALE

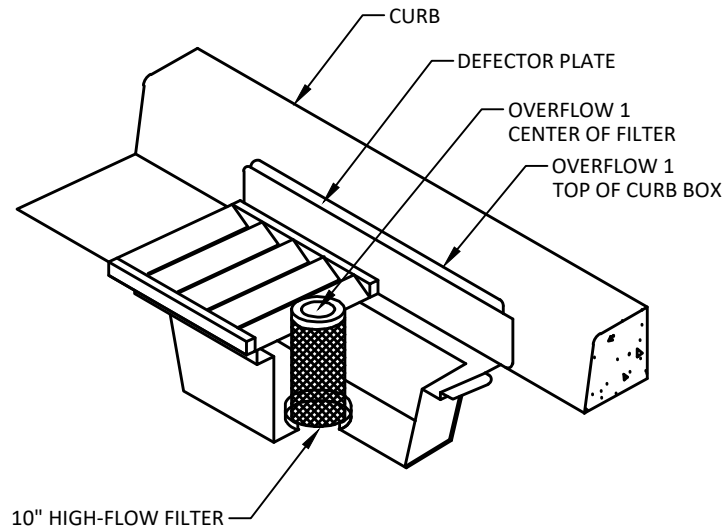

NOTE: WIMCO CG MODEL OR APPROVED EQUAL TO MATCH CASTING

**INLET PROTECTION
ROAD DRAIN**
NOT TO SCALE

NOTES:

1. ROAD DRAIN DEVICE FITS NEENAH R-3067 CASTINGS.
2. PLACE THE ROAD DRAIN-TOP SLAB MODEL DIRECTLY INTO THE CASTING.
3. INSTALL GASKET AND COVER CENTER OF GASKET WITH PIPE GREASE OR OTHER APPROVED LUBRICATION.
4. PLACE THE FILTER MEDIA ONTO THE RISER PIPE.
5. ADJUST FILTER MEDIA PROPER HEIGHT FOR OVERFLOW.
6. CHECK RISER TUBE TO MAKE SURE IT IS FULLY EXTENDED AND ALL FILTER HOLES ARE EXPOSED.
7. CHECK FILTER MEDIA AFTER EACH RAIN EVENT. CLEAN OR REPLACE IF SEDIMENT CLOGS FILTER.
8. REMOVE SEDIMENT AND DEBRIS FROM THE BASE OF THE RISER PIPE TO THE WIDTH EQUAL TO THE SIZE OF THE TOP SLAB MODEL.

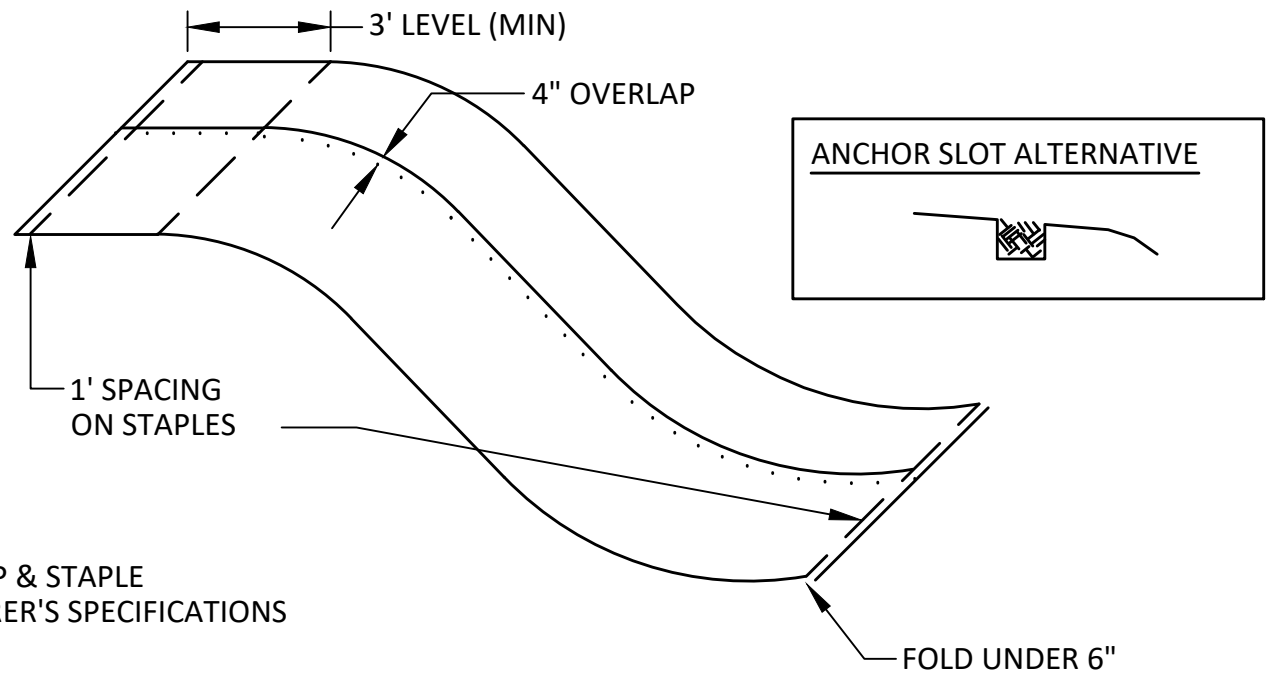

NOTE:
 ANCHOR, OVERLAP & STAPLE
 PER MANUFACTURER'S SPECIFICATIONS

EROSION CONTROL BLANKET INSTALLATION
 NOT TO SCALE



EROSION CONTROL BLANKET
 INSTALLATION



DATE:
 02/2020

STD. DETAIL
 3-200

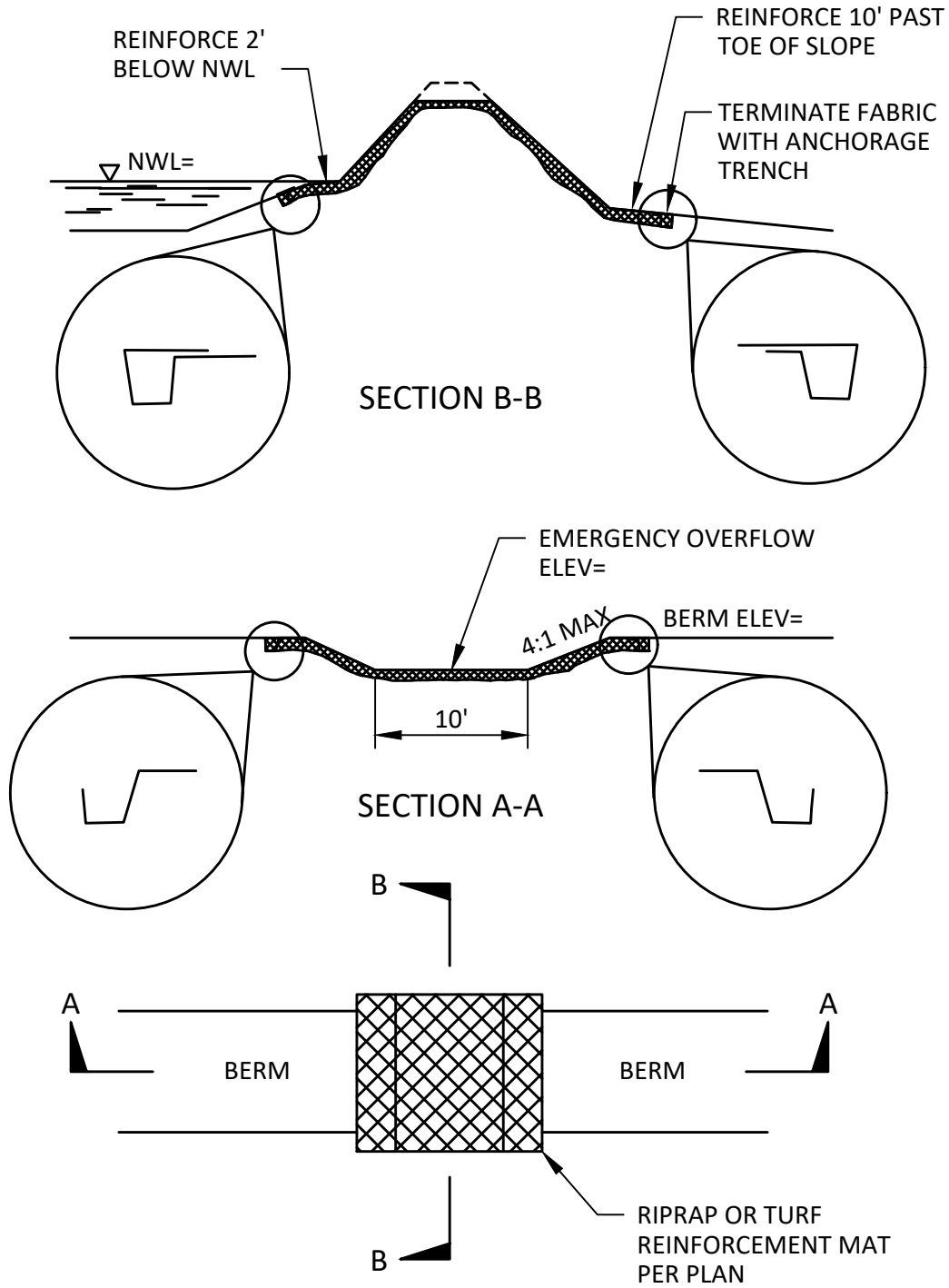

EROSION CONTROL BLANKET
AT POND EOF
 NOT TO SCALE

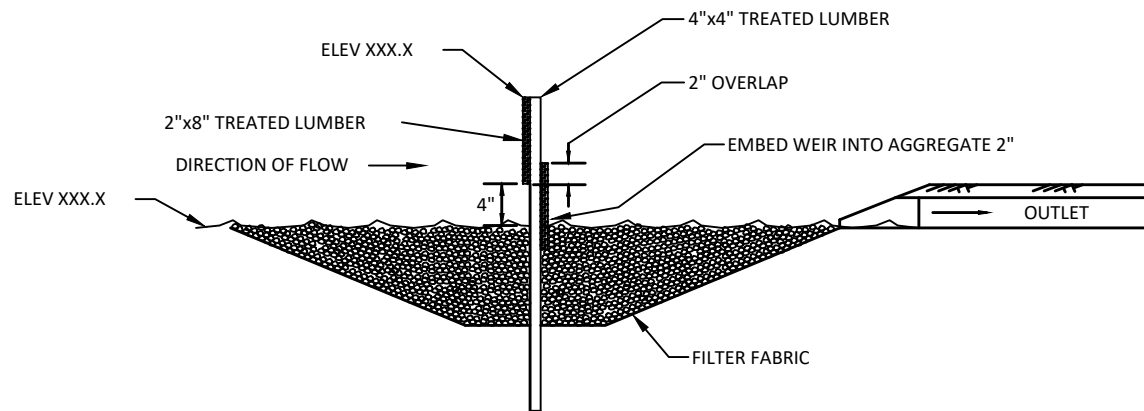
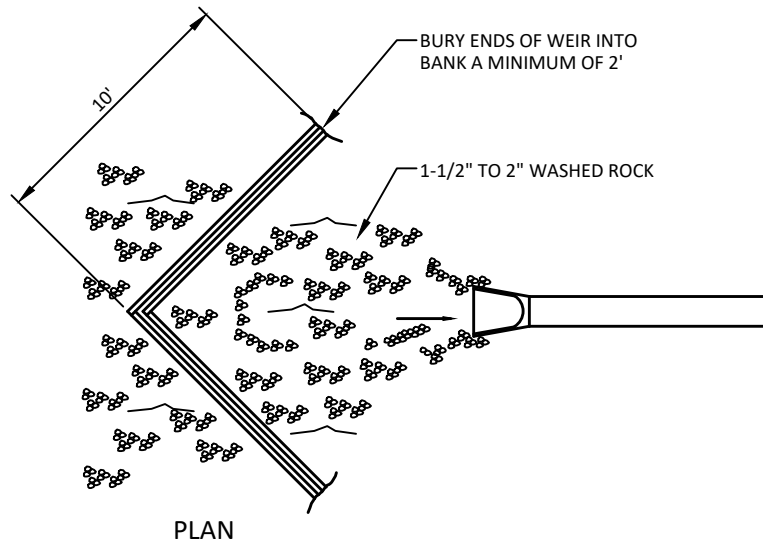

SKIMMER WEIR (POND OR WIDE CHANNEL)
NOT TO SCALE

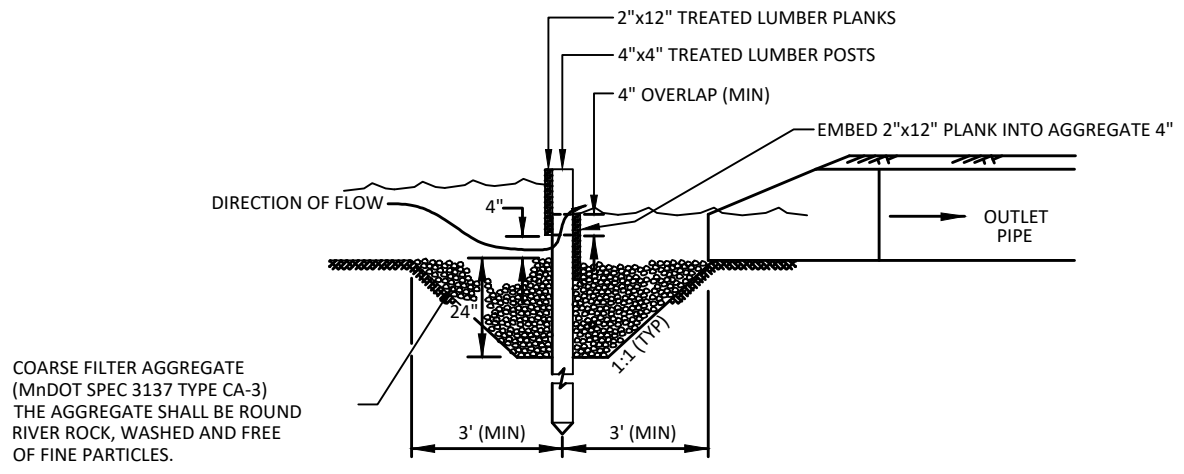
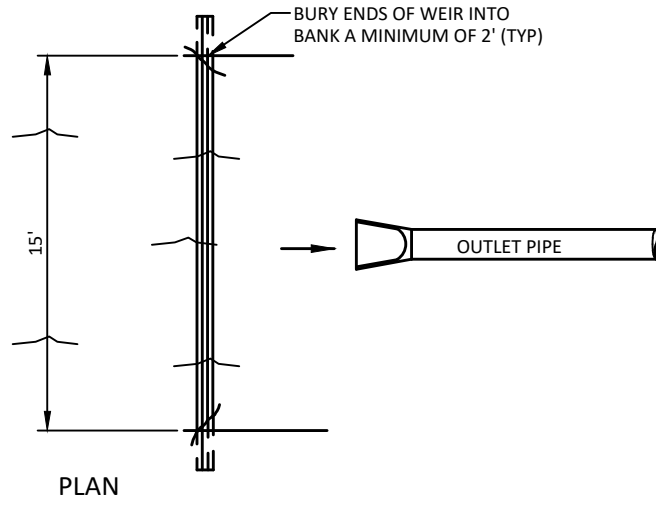

SKIMMER WEIR (NARROW CHANNEL)
NOT TO SCALE



**SKIMMER WEIR
(NARROW CHANNEL)**

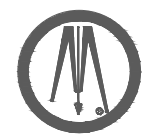

DATE:
02/2020

STD. DETAIL
3-203

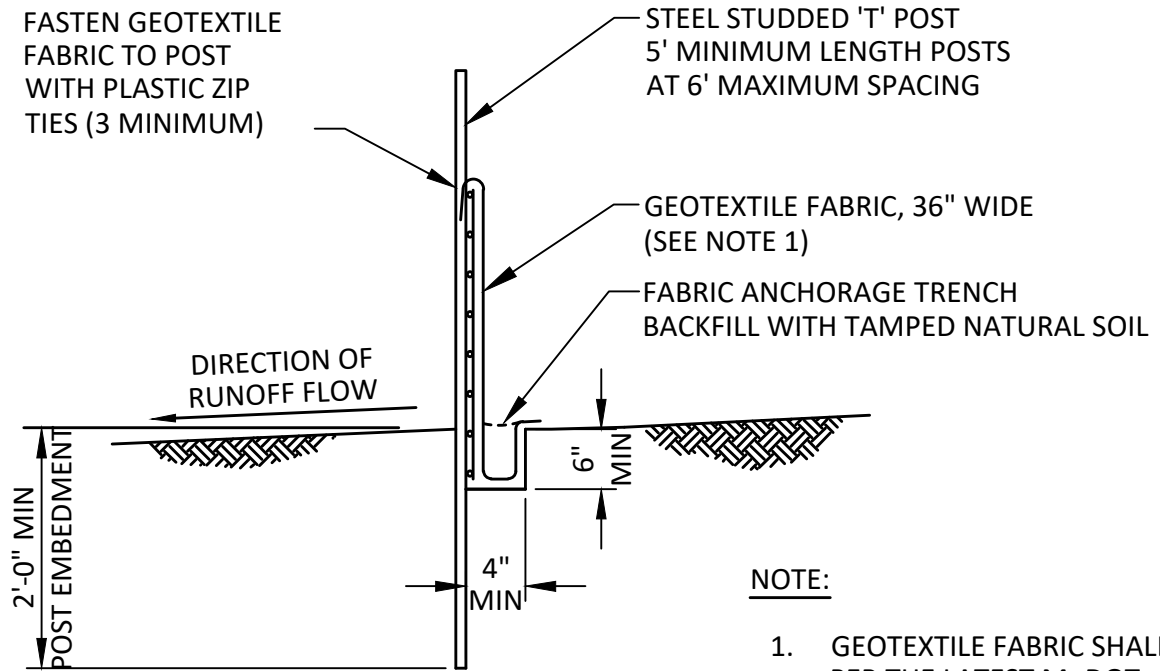

NOTE:

1. GEOTEXTILE FABRIC SHALL BE PER THE LATEST MnDOT SPECIFICATION OR TECH MEMO

SILT FENCE - HEAVY DUTY
NOT TO SCALE

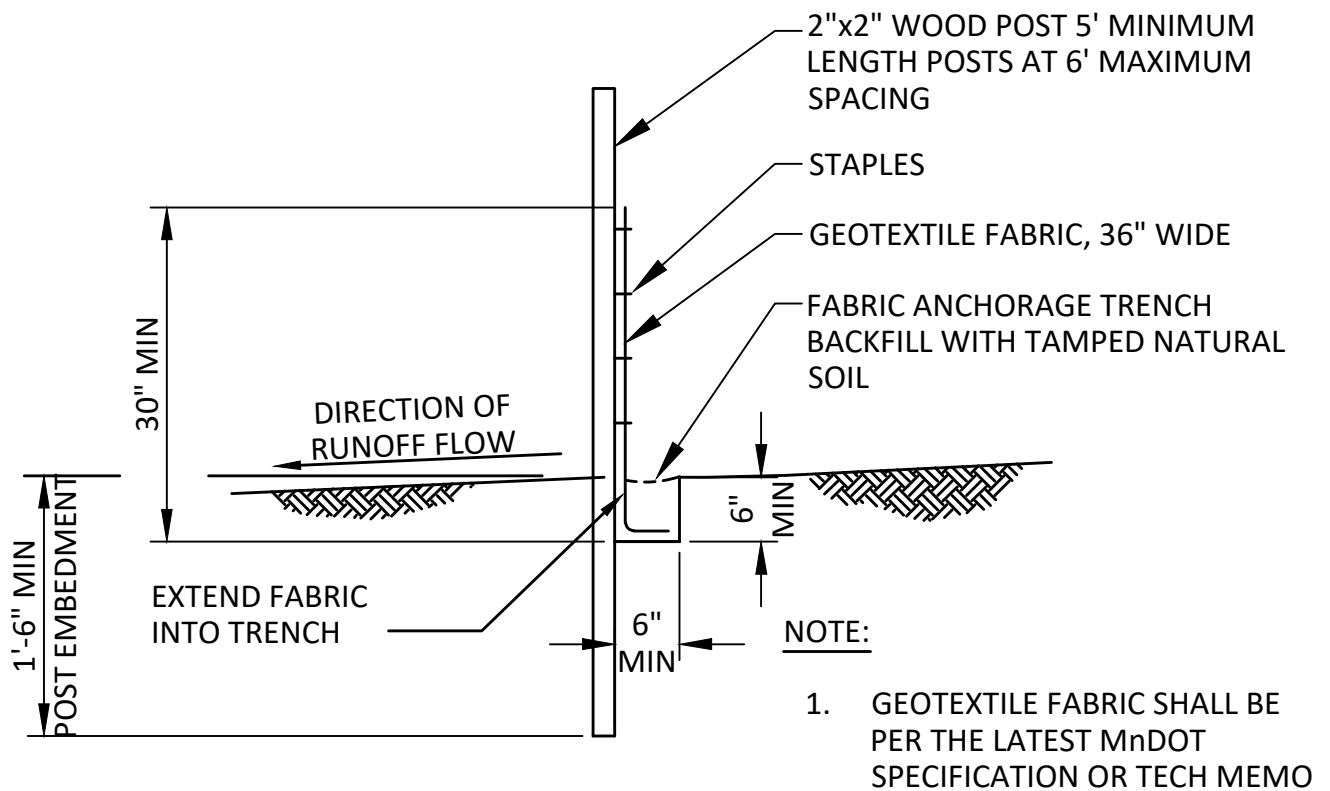

SILT FENCE - PREASSEMBLED

NOT TO SCALE

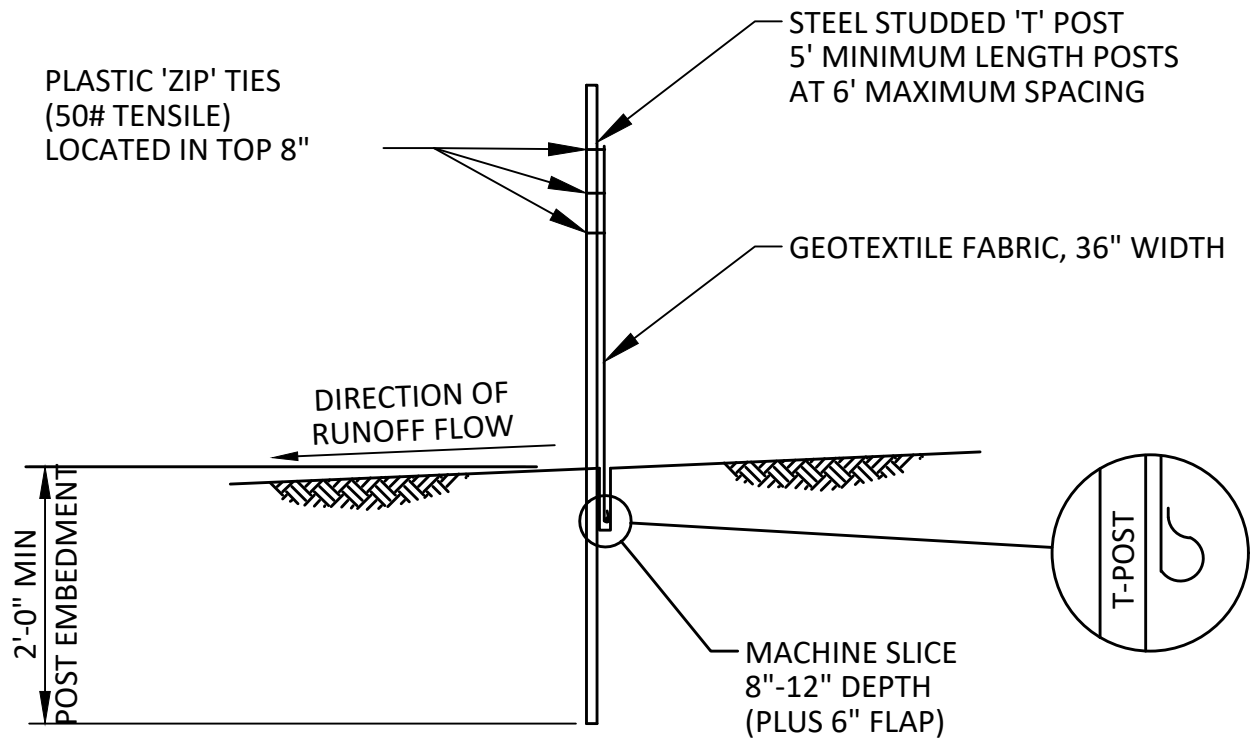

SILT FENCE - MACHINE SLICED

NOT TO SCALE

NOTE:

1. GEOTEXTILE FABRIC SHALL BE PER THE LATEST MnDOT SPECIFICATION OR TECH MEMO

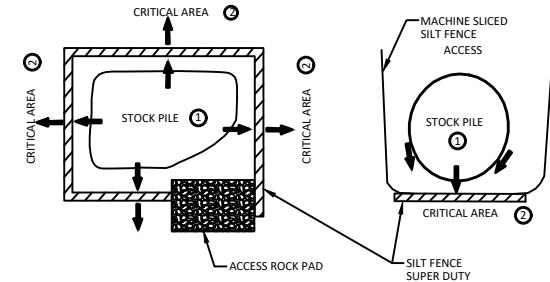
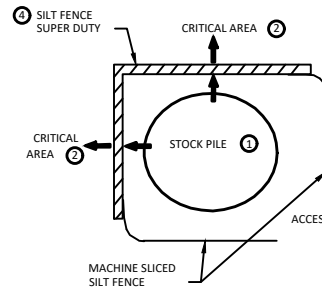
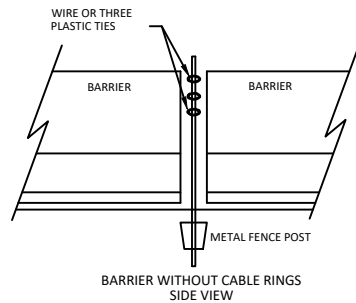
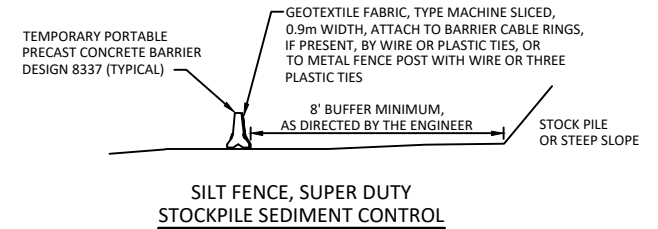
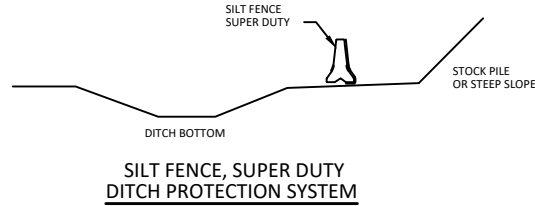
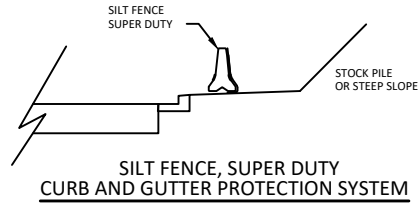

SILT FENCE, SUPER DUTY STOCKPILE CONTAINMENT

NOTES:

1. PLACING STOCK PILES NEXT TO AN ENVIRONMENTALLY SENSITIVE AREA IS NOT RECOMMENDED. WHEN THERE ARE NO FEASIBLE ALTERNATIVES, THE SUPER DUTY SILT FENCE IS TO BE USED AS SHOWN OR AS DIRECTED BY THE ENGINEER.
2. CRITICAL AREAS INCLUDE WETLANDS, JUDICIAL DITCHES, STREAMS, WATER BODIES, AND OTHER AREAS REQUIRING PROTECTION.
3. GEOTEXTILE FABRIC, TYPE WOVEN MONOFILAMENT CONFORMING TO SPEC 3886, TABLE 3886-1.
4. INSTALL TO FIT LAND FORM AND ITEM TO PROTECT.

SILT FENCE TEMPORARY SEDIMENT CONTROL

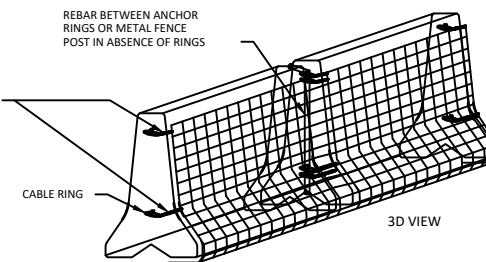
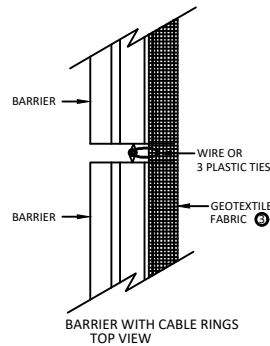
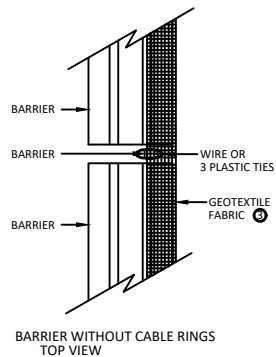

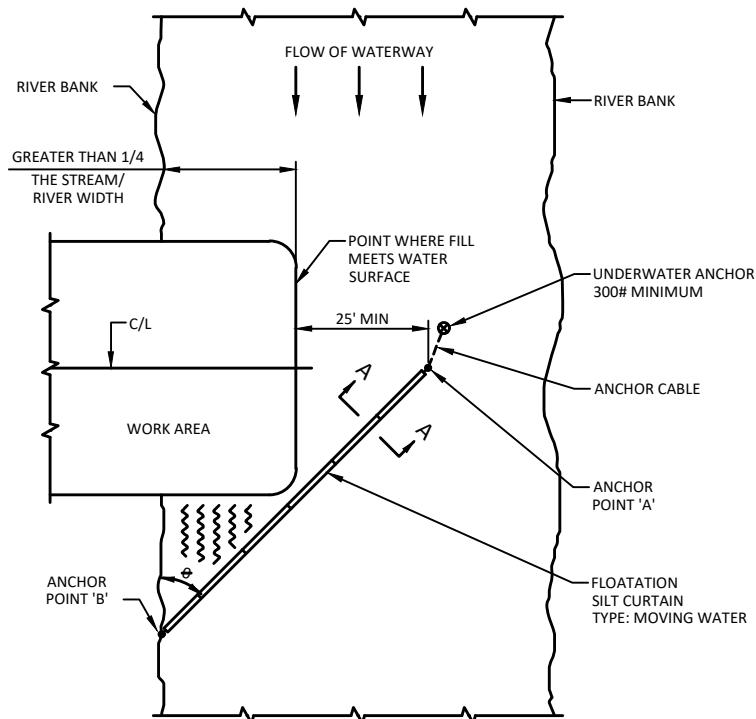

∠ ⊕	RIVER VELOCITY
45°	SLOW, LESS THAN 3 FT/SEC
35°	MODERATE, 3 - 5 FT/SEC

PLAN VIEW

DESIGN GUIDELINES:
 WHEN TEMPORARY FILL ENCLOSES MORE THAN 1/4 BUT LESS THAN 1/3 THE WIDTH OF THE STREAM

MAXIMUM WATER DEPTH: 11 FT
 MINIMUM WATER DEPTH: 3 FT
 MAXIMUM WATER VELOCITY: 5 FT/SEC

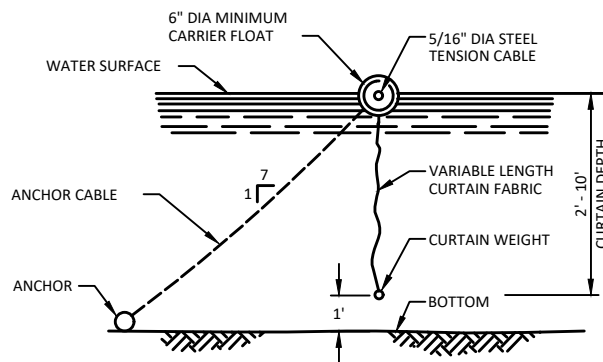

SECTION A-A

SILT FENCE - FLOTATION SILT CURTAIN
 NOT TO SCALE

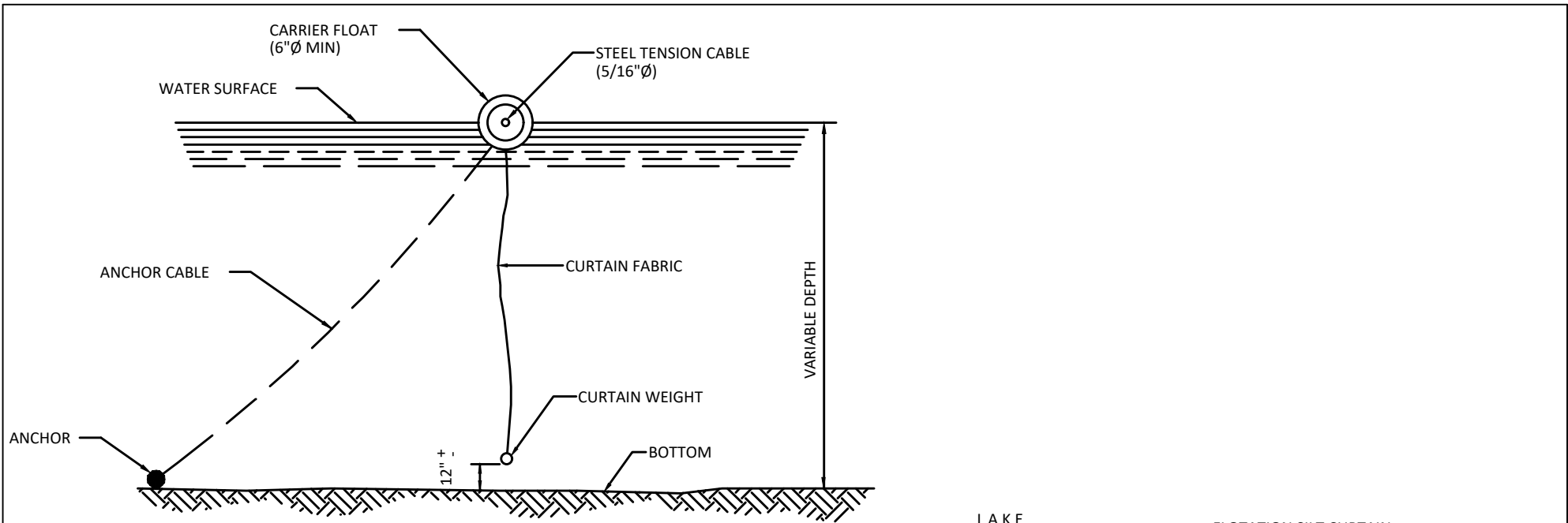

PROFILE VIEW

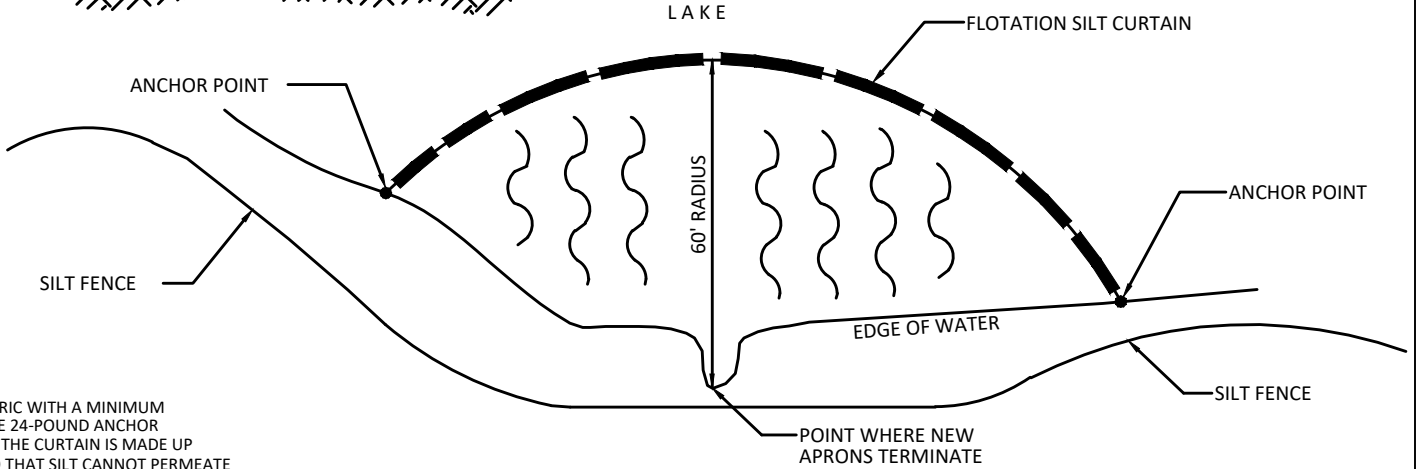

PLAN VIEW

NOTE: CURTAIN SHALL BE CONSTRUCTED OF A NYLON FABRIC WITH A MINIMUM TENSILE STRENGTH OF 300 LBS./IN. OF FABRIC. ONE 24-POUND ANCHOR SHALL BE USED PER 100 FEET OF CURTAIN. WHERE THE CURTAIN IS MADE UP OF SECTIONS, THE SECTIONS SHOULD BE JOINED SO THAT SILT CANNOT PERMEATE THROUGH THE CONNECTION.

FLOTATION SILT CURTAIN - STILL WATER

N.T.S.



SILT FENCE
FLOTATION SILT CURTAIN
(STILL WATER)



DATE:
02/2020

STD. DETAIL
3-405

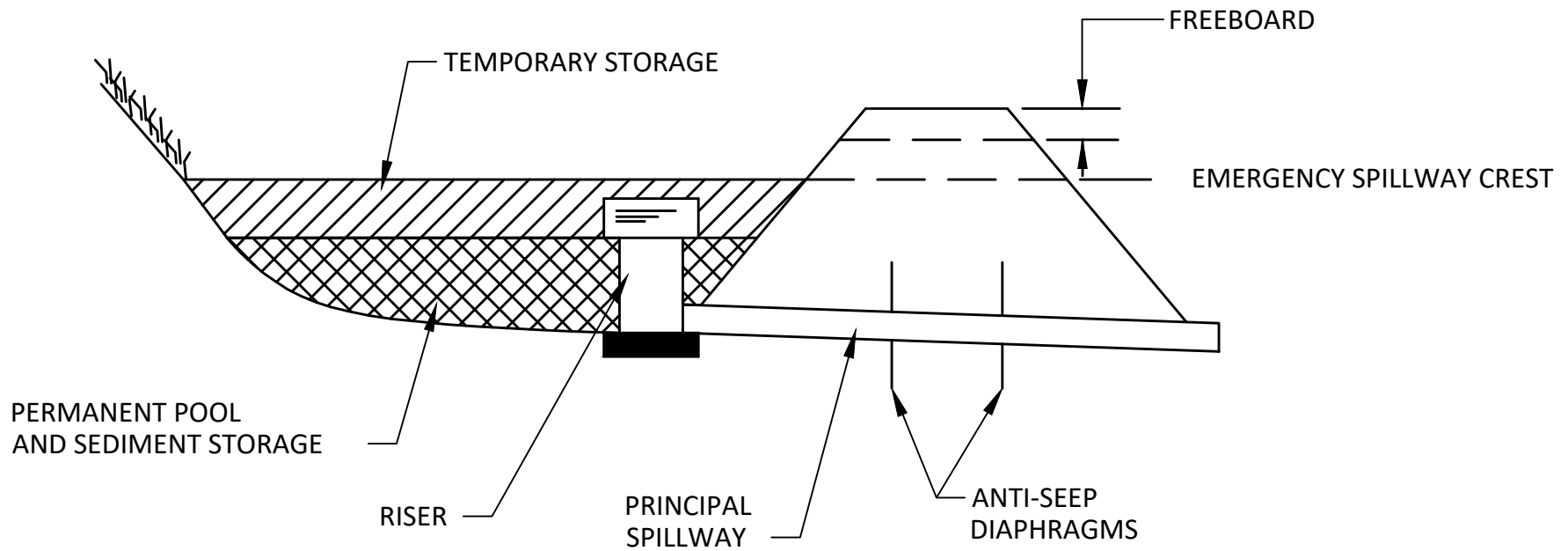

TYPICAL SEDIMENT BASIN CROSS SECTION

NOT TO SCALE

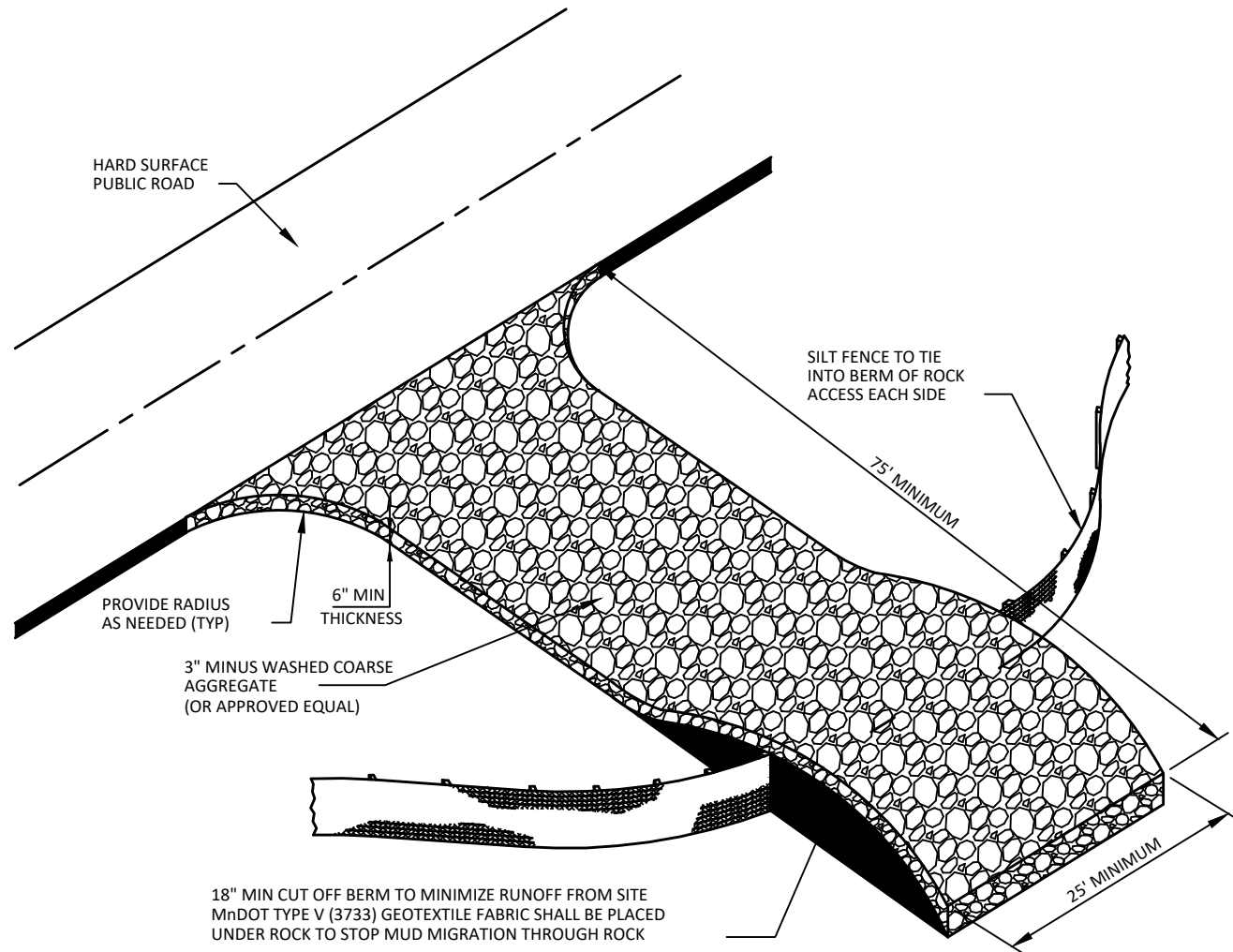

ROCK CONSTRUCTION ENTRANCE

NOT TO SCALE

SEE TABLE FOR
MINIMUM DEPTH

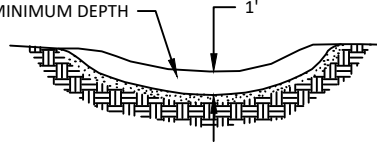

SECTION B-B

DIA OF ROUND PIPE (IN)	L (FT)	CLASS III d50=9"	CLASS IV d50=12"
		18" DEPTH RIPRAP (CU YD)	24" DEPTH RIPRAP (CU YD)
12	8	8	10
15	8	8	10
18	10	10	15
21	10	15	15
24	12	15	20
27	12	15	20
30	14	20	25
36	16	25	30
42	18	30	40
48	20	40	50

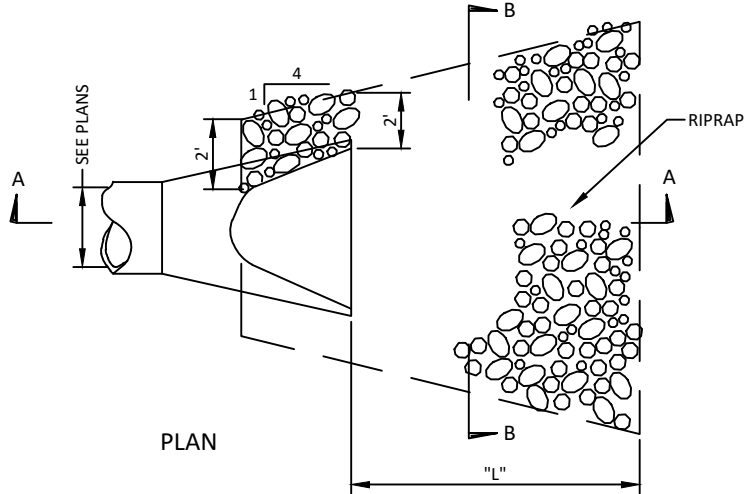

PLAN

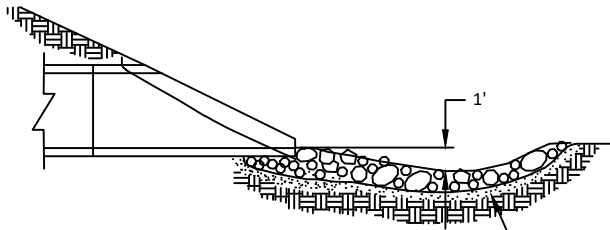

GEOTEXTILE FABRIC, PER Mn/DOT SPEC 3733;
THE FABRIC SHOULD COVER THE AREA
OF THE RIPRAP AND EXTEND UNDER
THE CULVERT APRON THREE FEET

SECTION A-A

RIPRAP AT RCP CULVERT END

NOT TO SCALE



RIPRAP AT RCP
CULVERT END



DATE:
02/2020

STD. DETAIL
3-600

NOTE:
ALL EROSION CONTROL MEASURES TO BE MAINTAINED
THROUGHOUT THE CONSTRUCTION PROCESS. STREET
TO BE KEPT CLEAN AT ALL TIMES.

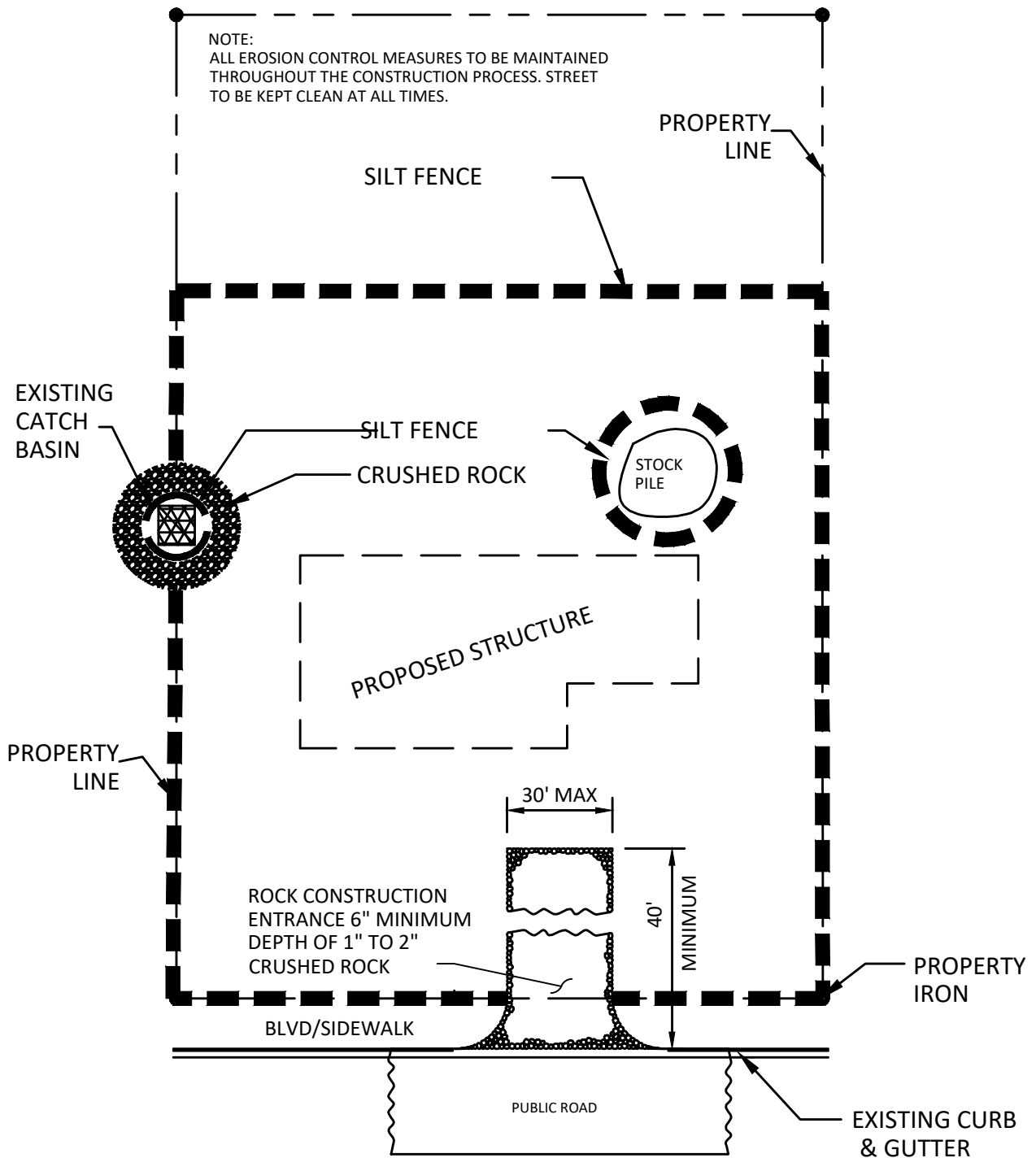

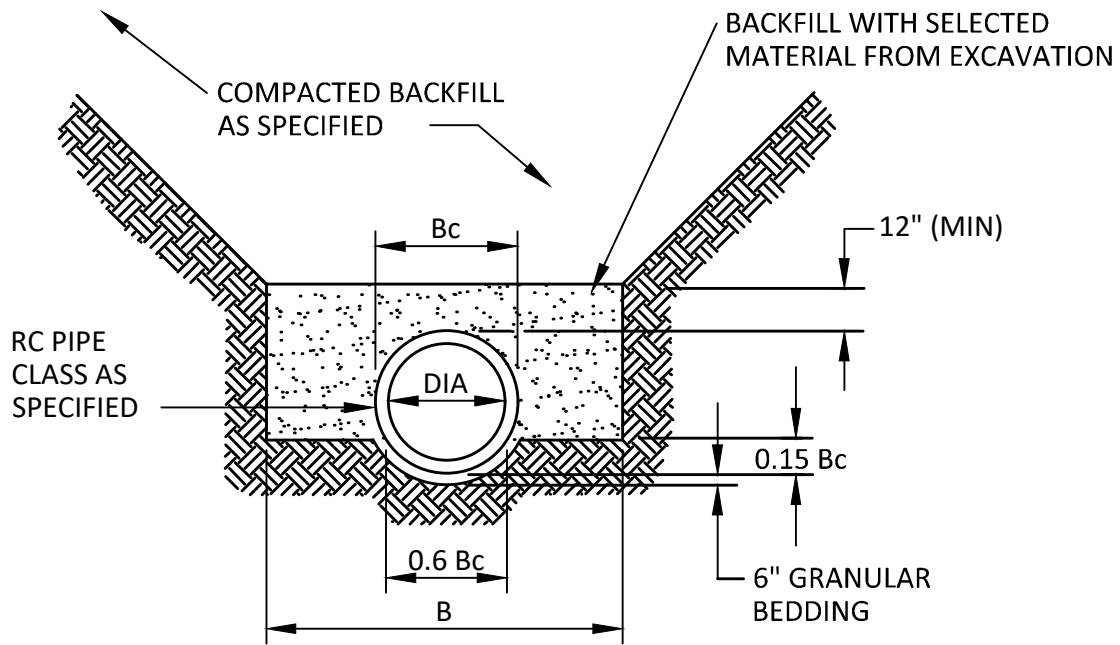

PIPE DIA	B
36" OR LESS	$B_c + 24"$
42" TO 54"	$1.5 \times B_c$
60" OR OVER	$B_c + 36"$

RC PIPE
CLASS "B" BEDDING
 NOT TO SCALE

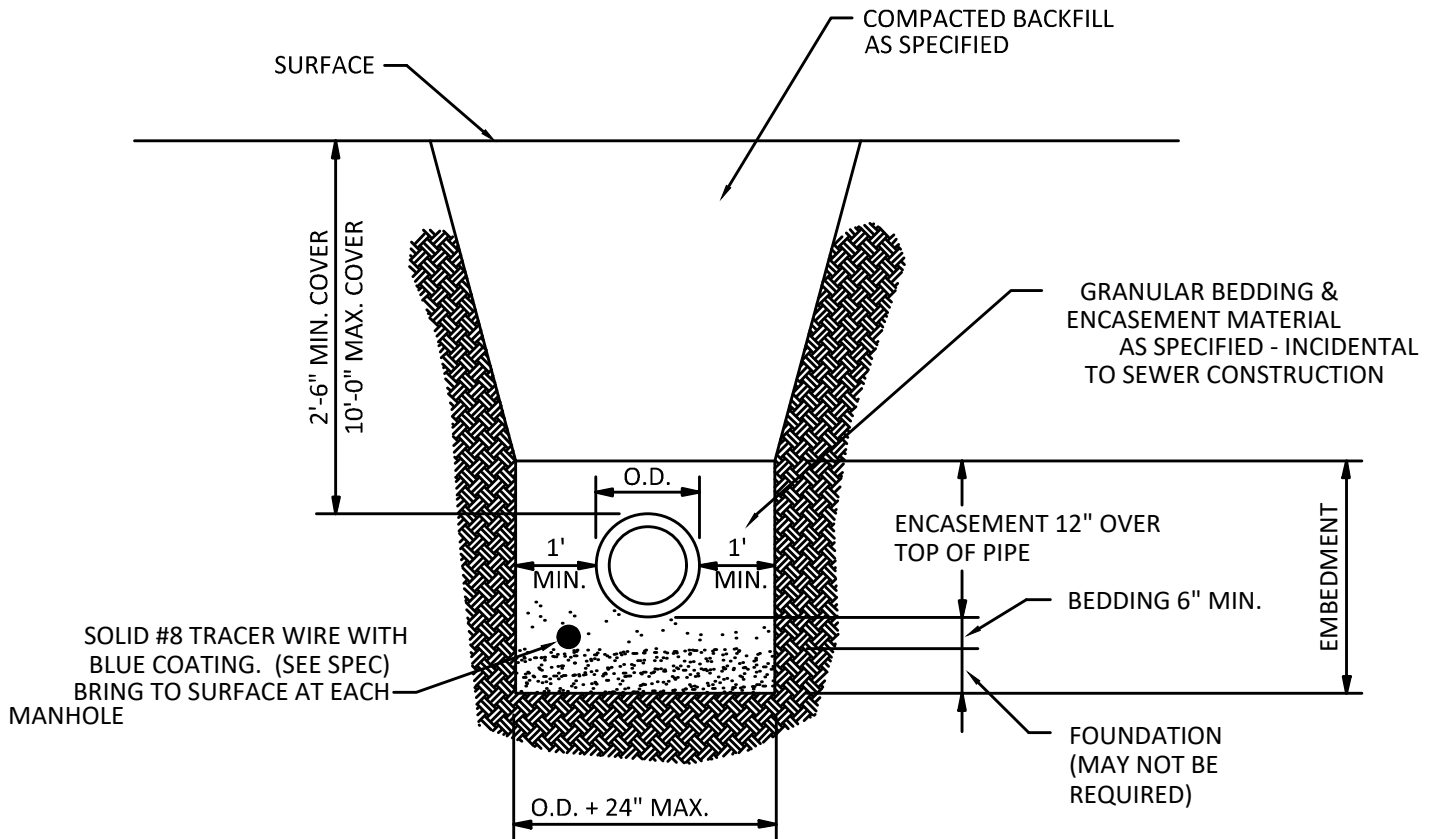

NOTES:

1. THIS PLASTIC PIPE INSTALLATION DETAIL APPLIES ONLY TO STORM SEWER.
2. MAXIMUM PIPE DIAMETER IS 24".
3. PIPE MATERIAL REQUIREMENTS PER CURRENT AASHTO REQUIREMENTS.
4. EMBEDMENT MATERIAL PER SPEC. 3149.2D MODIFIED TO 100% PASSING THE 1" SIEVE.
5. CONSTRUCTION REQUIREMENTS PER SPEC. 2451 MODIFIED SO THAT EMBEDMENT MATERIAL IS COMPACTED IN UNIFORM LIFTS, 8" OR LESS IN DEPTH, LOOSE MEASURE, TO 95% STANDARD PROCTOR DENSITY FROM THE BEDDING TO A MIN. DEPTH OF AT LEAST 12" ABOVE THE CROWN OF THE PIPE.
6. BEDDING TO BE CLASS C PER SPEC. 2451.3.
7. TRENCH WIDTH PER ASTM D2321 EXCEPT AS MODIFIED TO PROVIDE A MINIMUM OF 1-FOOT ON EACH SIDE OF THE PIPE TO ALLOW FOR COMPACTION.
8. COST FOR FURNISHING AND INSTALLING GRANULAR BEDDING AND ENCASEMENT MATERIALS SHALL BE INCLUDED IN THE PRICE BID FOR OPEN PROFILE WALL POLYVINYL CHLORIDE (PVC) PIPE

PVC STORM SEWER TRENCH DETAIL
NOT TO SCALE

CONCRETE COLLAR
TO ENCASE CASTING
AND ADJUSTMENT RINGS

CASTING: NEENAH R-4342
OR APPROVED EQUAL

MIN. 2 MAX. 4 CONCRETE
ADJUSTING RINGS MORTARED
INSIDE AND OUT
MINIMUM 1/2" THICKNESS

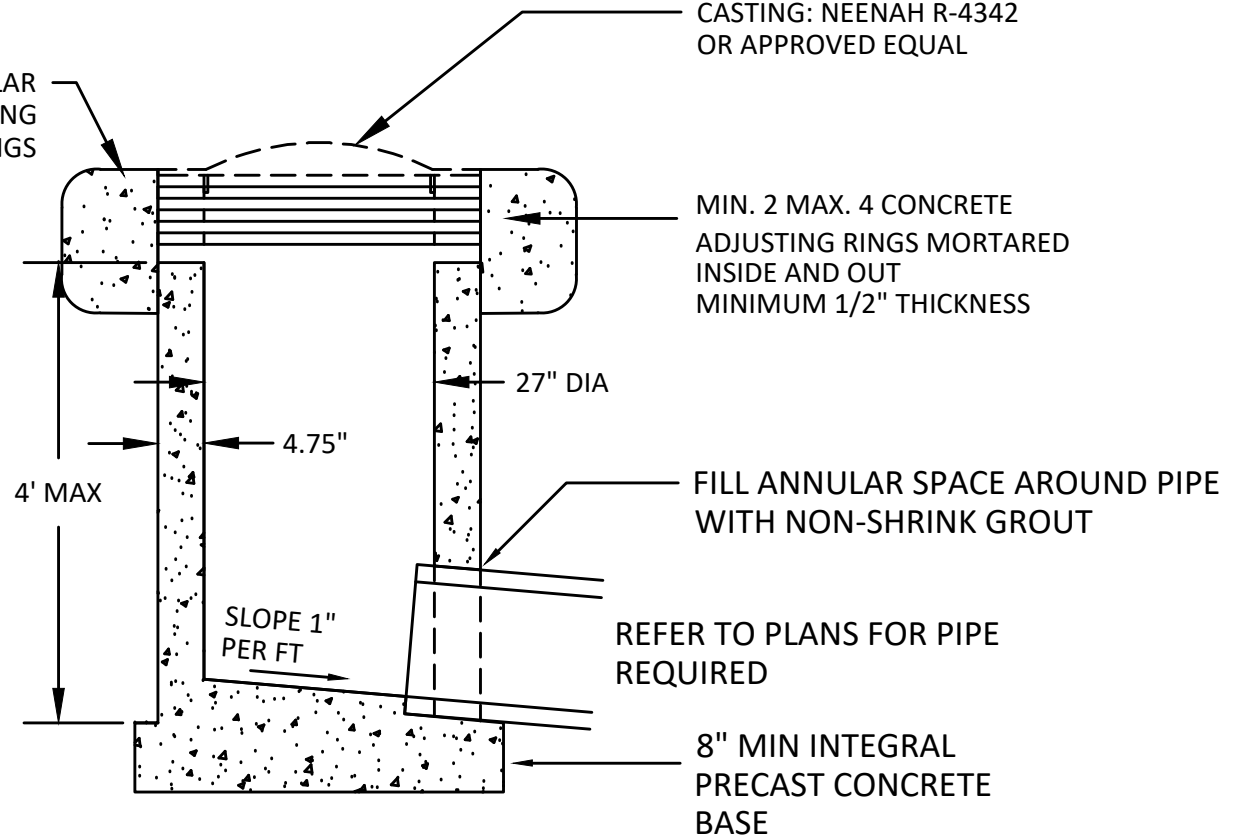

CATCH BASIN
DESIGN H
NOT TO SCALE

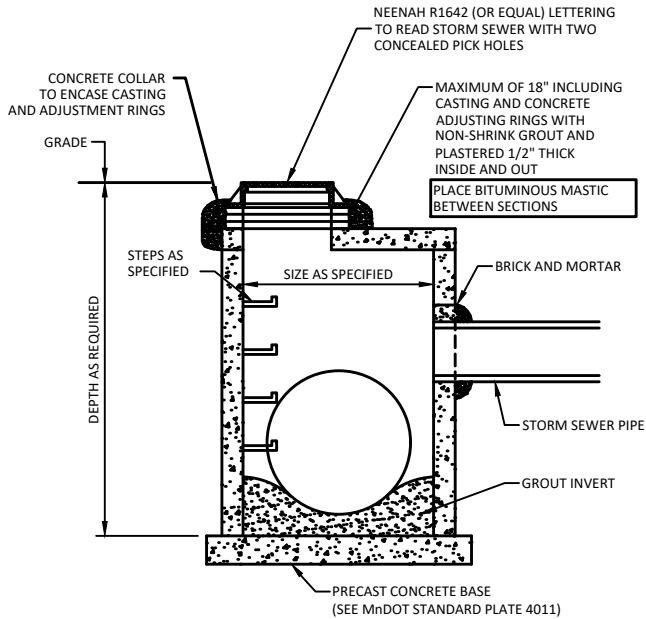

TYPICAL DESIGN 4020 MANHOLE/CATCH BASIN

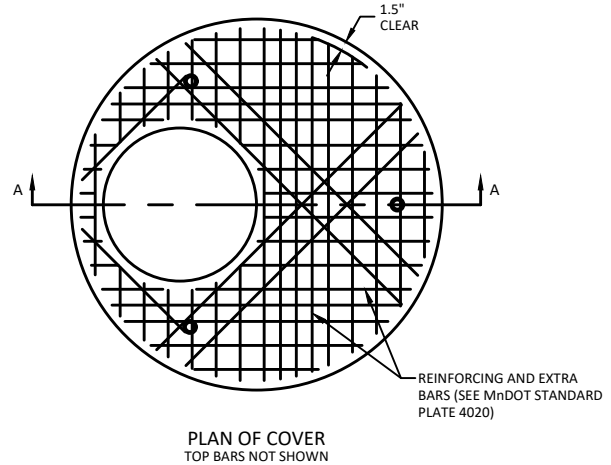

PLAN OF COVER
TOP BARS NOT SHOWN

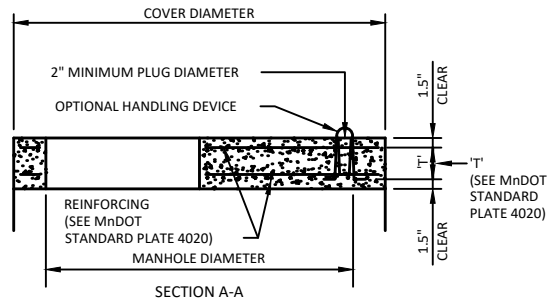

SECTION A-A

NOTES:

1. AASHTO HS 25 LOADING MAXIMUM FILL HEIGHT 15'.
2. THE No 4020 SHALL BE PERMANENTLY MARKED ON THE TOP COVER.
3. EQUIVALENT STEEL AREAS IN WIRE MESH MAY BE USED.
4. REINFORCEMENT PER SPEC 3301, GRADE 60 A SINGLE HOOP OF 8ga STEEL WIRE.

DESIGNATION:
DESIGN: STANDARD PLATE #-DESIGN
DESIGN 4020-48

**STORM SEWER STRUCTURE
DESIGN 4020
NOT TO SCALE**

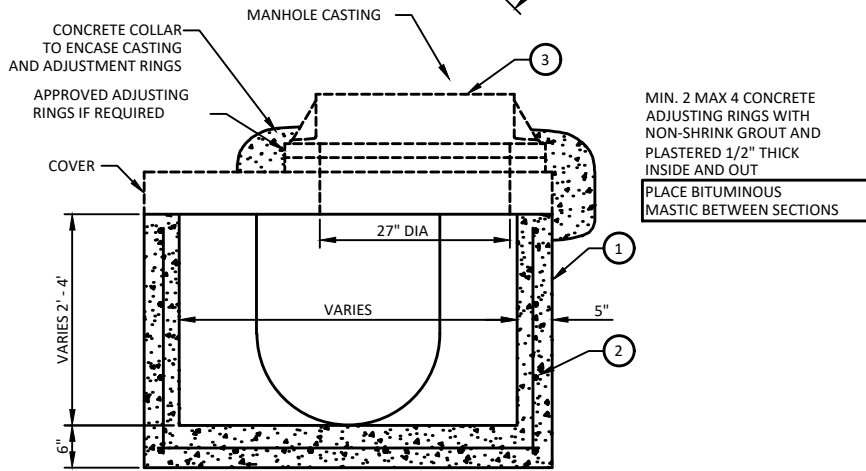
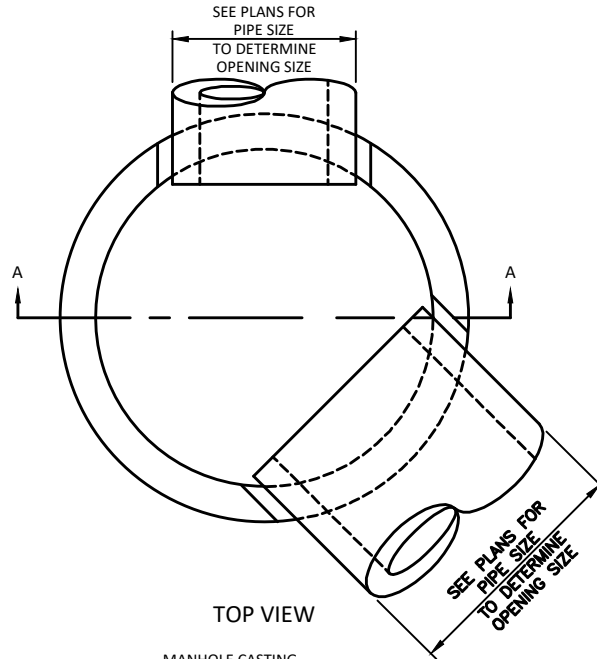

SECTION A-A

STANDARD OPENINGS	
PIPE DIA (INCHES)	OPENING SIZE (INCHES)
12	20
15	24
18	26
21	30
24	34

- NOTES:
- ① BRICK OR CONCRETE BLOCK MASONRY MAY BE USED, AS APPROVED BY THE ENGINEER. FOR MATERIALS AND CONSTRUCTION METHODS, SEE STANDARD PLATE NO 4-001 DO NOT APPLY.
 - ② REINFORCING: SINGLE LINE STEEL WIRE FABRIC HAVING AN AREA OF NOT LESS THAN 0.12 SQ IN PER FOOT.
 - ③ COVER AND CASTING AS SPECIFIED.

**PRECAST SHALLOW DEPTH
MANHOLE/CATCH BASIN, DESIGN SD**
NOT TO SCALE



**PRECAST SHALLOW
DEPTH MH/CB
DESIGN SD**



DATE:
02/2020

STD. DETAIL
4-107

NOTES:

1. ECCENTRIC CONE SECTION MAY BE USED IN DEEP STRUCTURES TO AVOID MORE THAN 3 ADJUSTING RINGS.
2. PIPE CUT-OUTS TO BE LOCATED AS SPECIFIED.
3. STEEL REINFORCED PLASTIC STEPS SHALL BE A POLYPROPYLENE PLASTIC REINFORCED WITH A NO. 2 DEFORMED STEEL ROD GRADE 60.

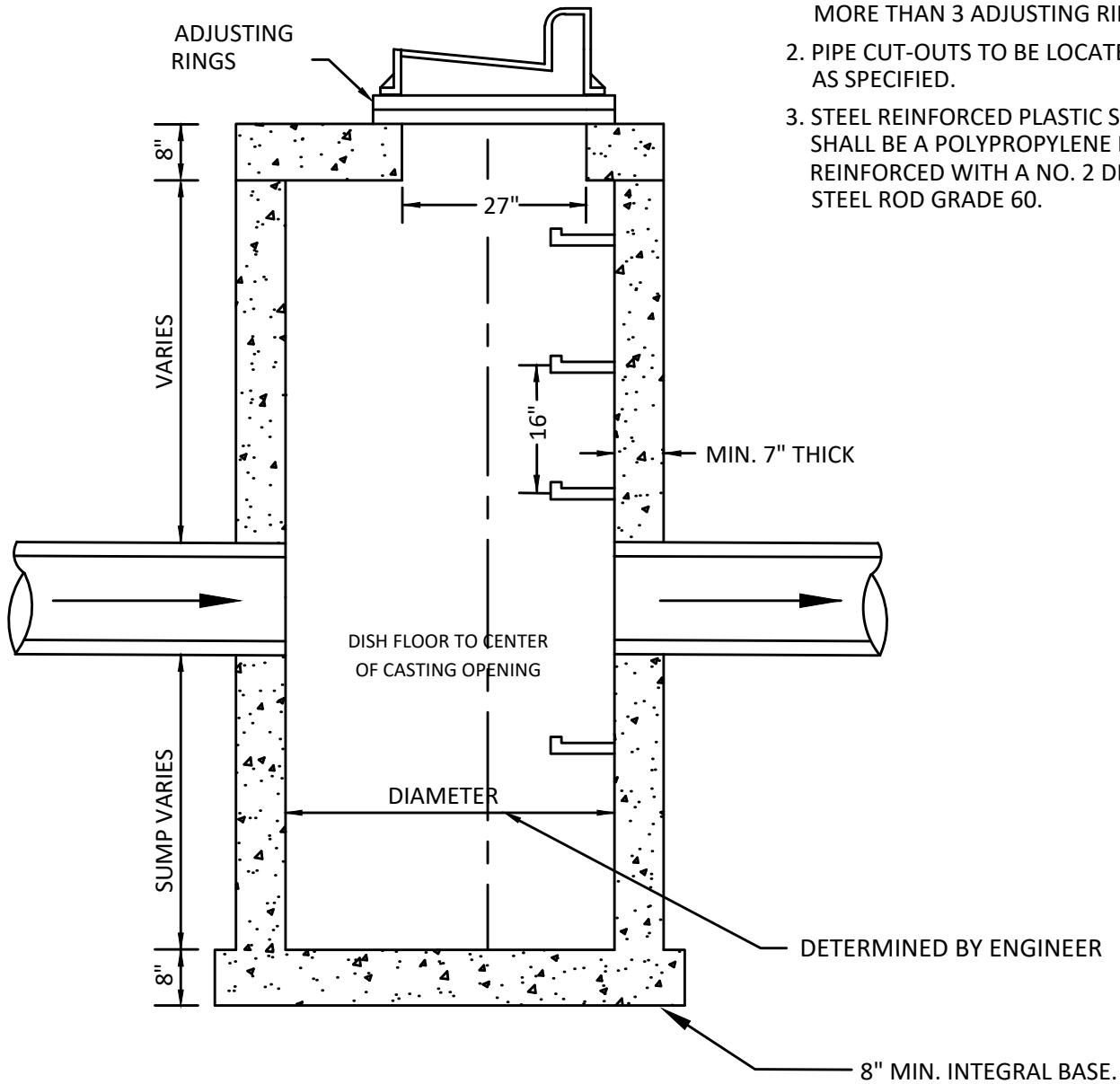

SECTIONAL VIEW

DRAINAGE STRUCTURE WITH SUMP
NOT TO SCALE

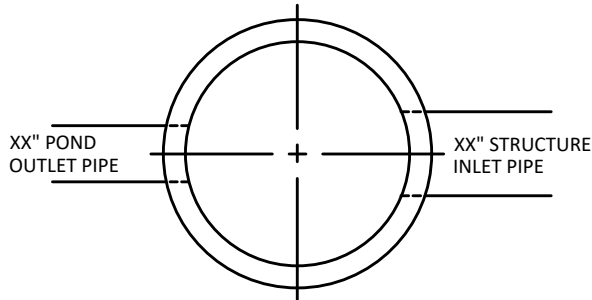

GRATE NOTES:

1. GRATE TO BE MADE IN TWO (2) PIECES
2. ALL METAL SHALL BE HOT-DIPPED GALVANIZED

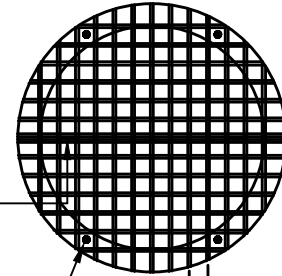

HINGE ASSEMBLY
MINIMUM OF 2
HINGES REQUIRED

(4) 1/2" DIA-13 UNC
HEX HEAD STAINLESS
STEEL BOLTS WITH NUTS
AND WASHERS

4" OC BOTH WAYS

**TWO-PIECE
POND SKIMMER GRATE
MIN 5/8" THICKNESS**

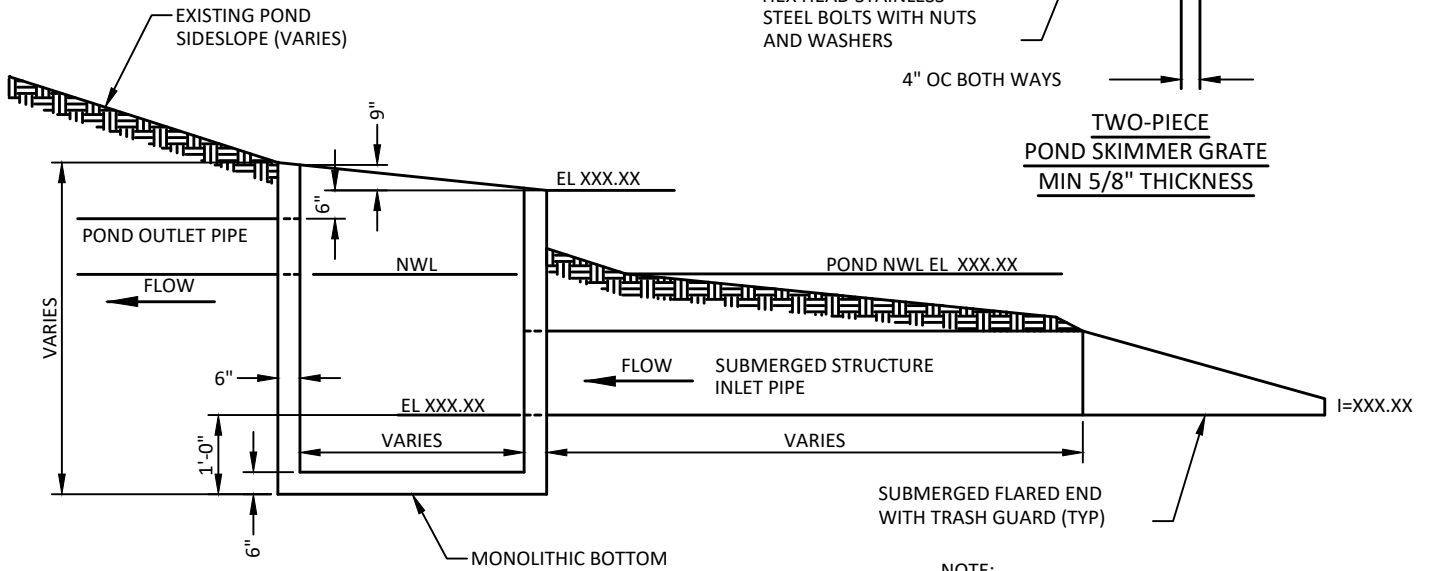

SECTION VIEW

NOTE:
1. ALL PIPE JOINTS SHALL BE TIED.

PRECAST CONCRETE POND SKIMMER STRUCTURE

NOT TO SCALE



**PRECAST CONCRETE
POND SKIMMER
STRUCTURE**



DATE:
02/2020

STD. DETAIL
4-200

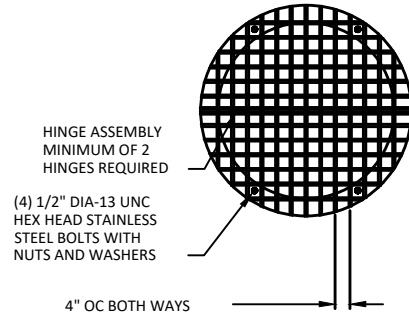
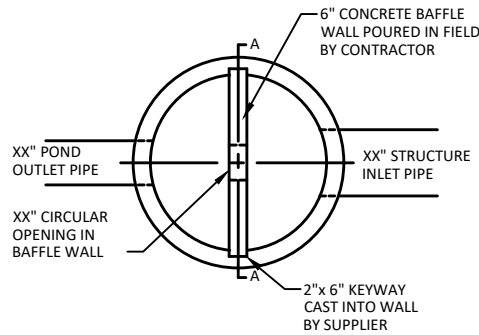

82" DIA (2) PIECE POND SKIMMER GRATE (MIN 5/8" THICKNESS)

- GRATE NOTES:
1. GRATE TO BE MADE IN TWO (2) PIECES
 2. ALL METAL SHALL BE HOT-DIPPED GALVANIZED

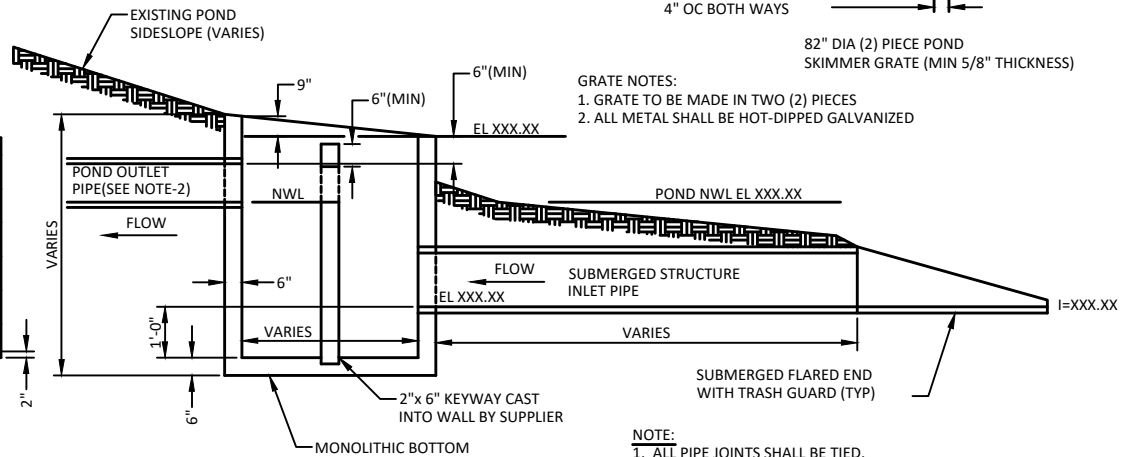
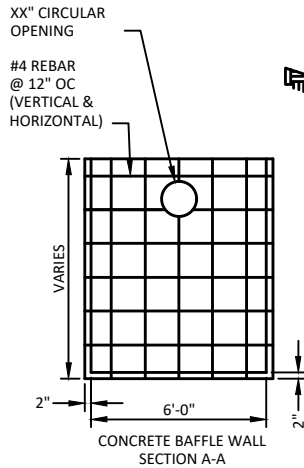

- NOTE:
1. ALL PIPE JOINTS SHALL BE TIED.
 2. BAFFLE WALL SHALL BE CONSTRUCTED TO PREVENT LEAKAGE AROUND THE WALL.

SECTION VIEW

PRECAST CONCRETE POND SKIMMER STRUCTURE WITH RATE CONTROL BAFFLE

NOT TO SCALE



PRECAST CONCRETE
POND SKIMMER
STRUCTURE W/RATE
CONTROL BAFFLE



DATE:
02/2020

STD. DETAIL
4-201

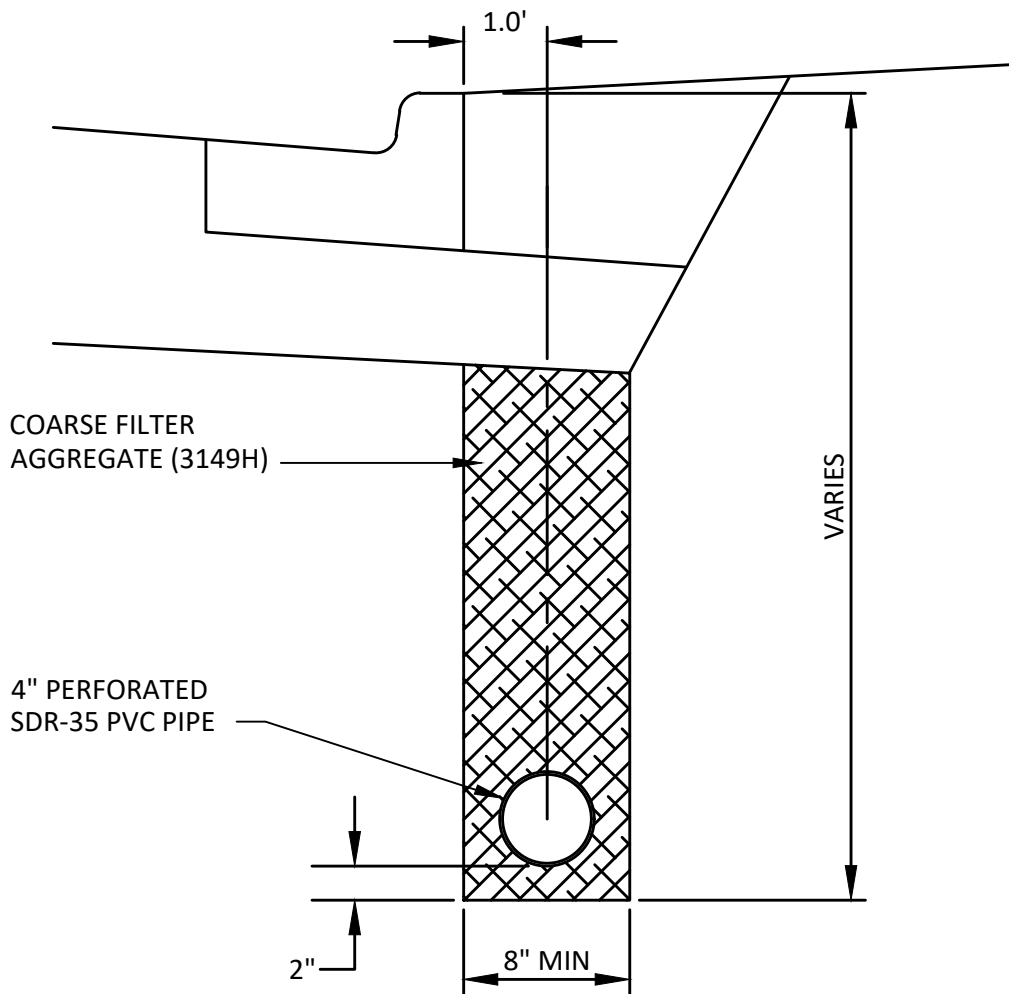

SUBSURFACE EDGE DRAIN
PVC PIPE
 NOT TO SCALE

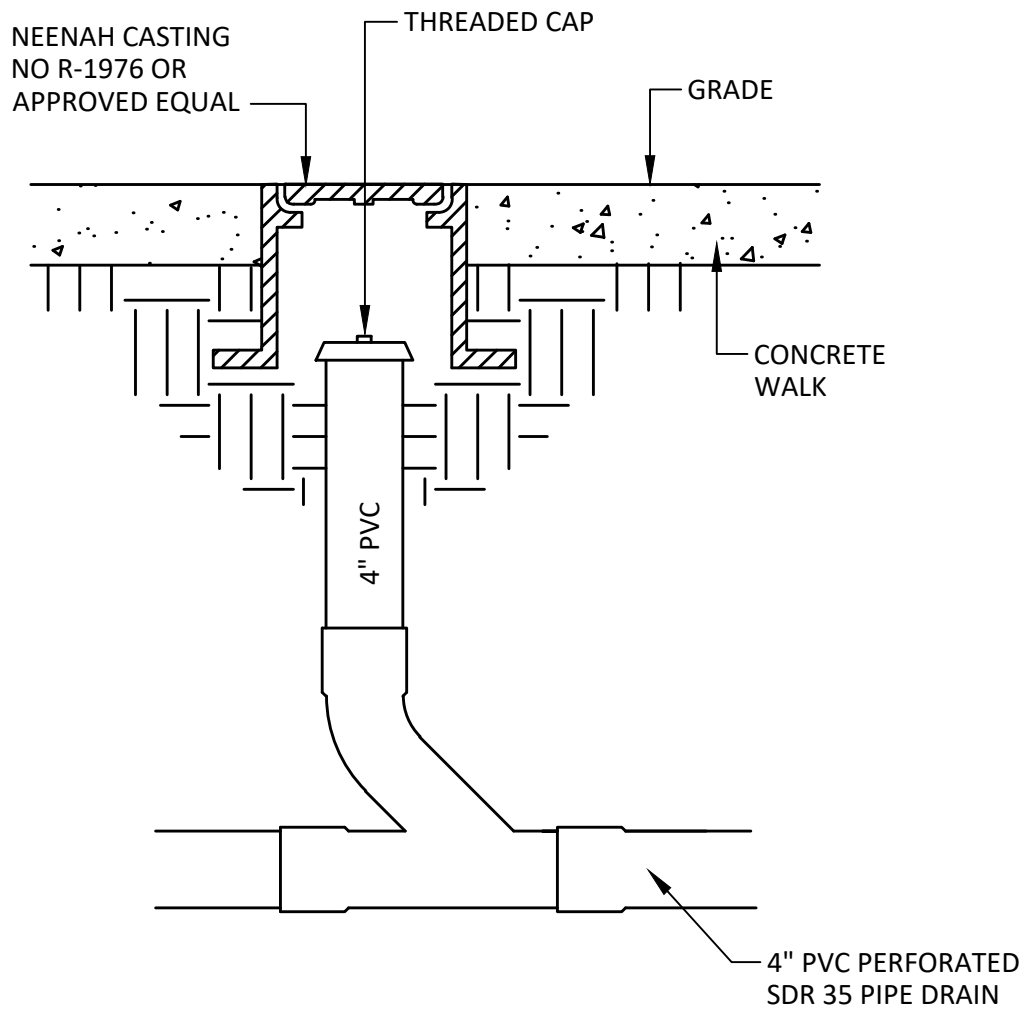

**SUBSURFACE DRAIN
CLEANOUT UNDER SIDEWALK**

NOT TO SCALE

METAL CAP OR 18"
STEEL PIN FOR LOCATING

THREADED CAP

GRADE

GRASS

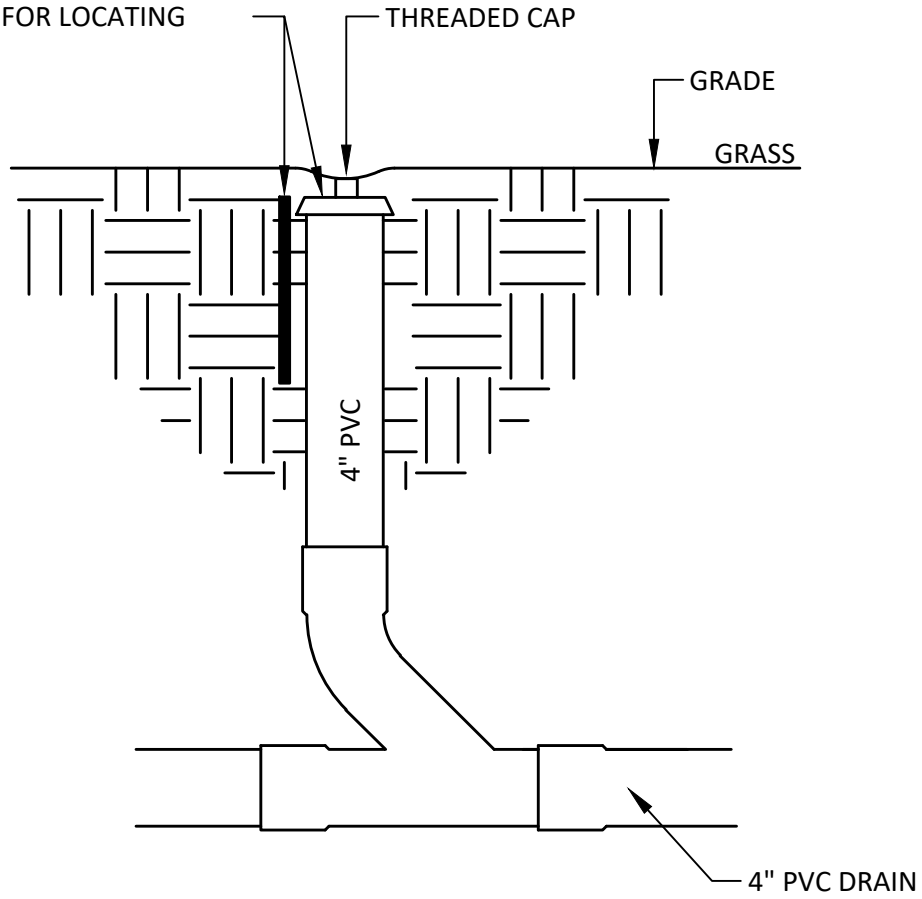

SUBSURFACE DRAIN CLEANOUT

NOT TO SCALE

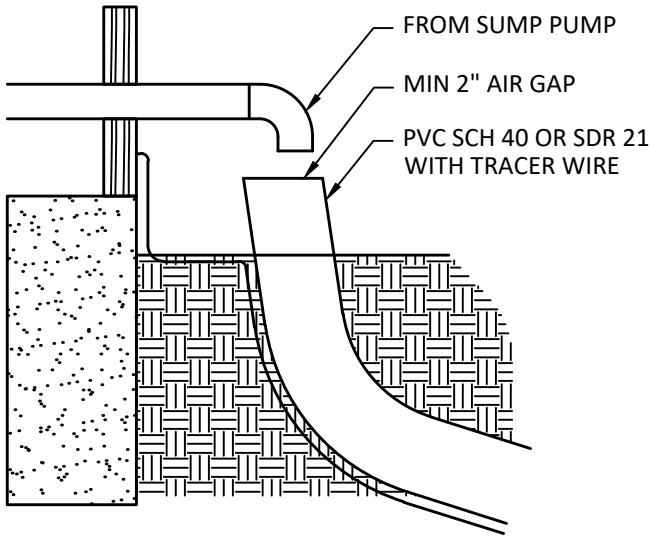

INSTALL DISCHARGE PIPE FROM HOUSE TO DAYLIGHT OUTLET, STORM SEWER STRUCTURE OR WATERBODY.

HOUSE CONNECTION

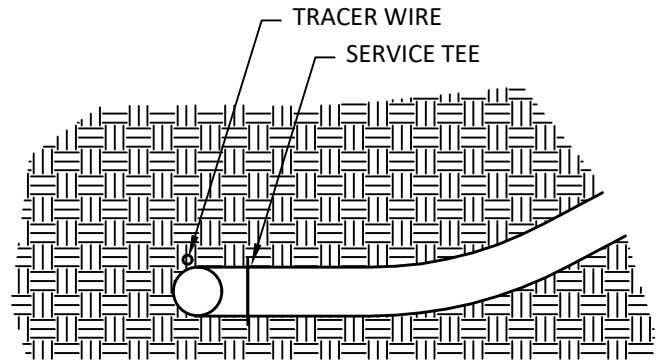

ALL COMMON DRAIN TILE SHALL HAVE A MINIMUM OF 18" COVER. ALL SERVICE DRAINTILE SHALL HAVE A MINIMUM OF 12" COVER TO TOP OF PIPE. BUILDER SHALL REMOVE CAP AT SERVICE AND MAKE CONNECTION TO DRAIN TILE.

SERVICE CONNECTION

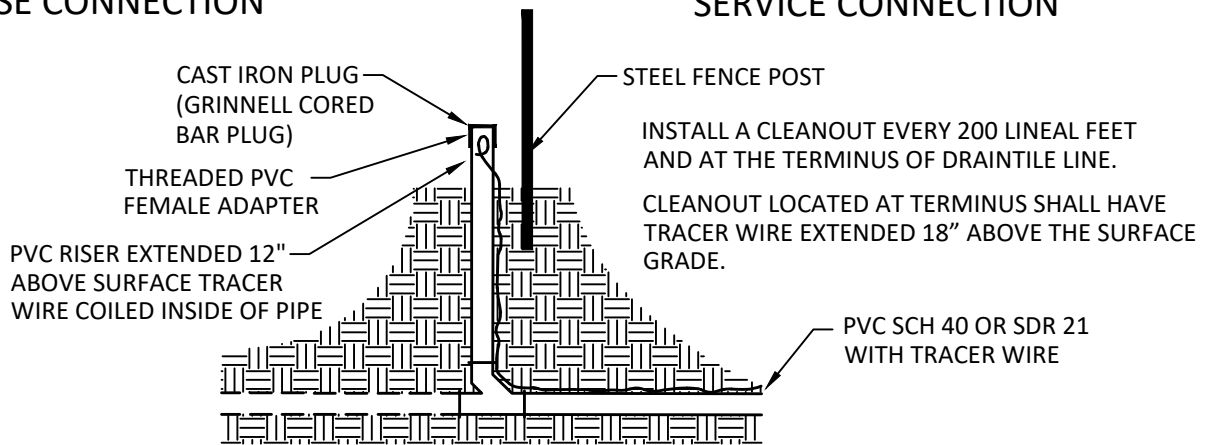

DRAINTILE CLEANOUT

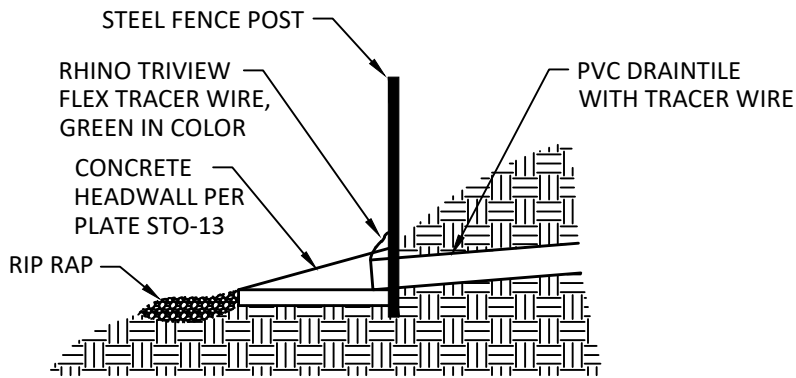

DRAINTILE OUTLET TO WATERBODY

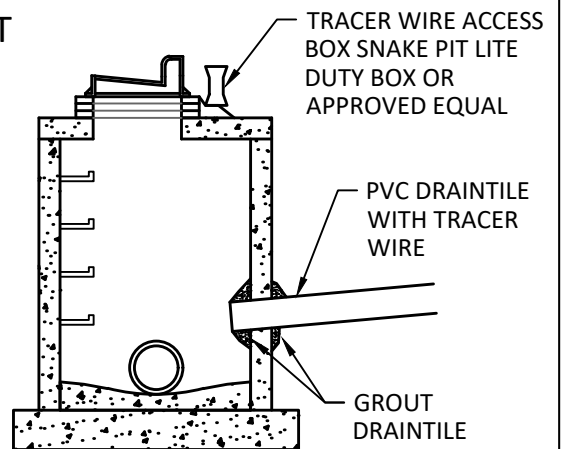

CONNECTION TO STORM SEWER

MINIMUM DRAINTILE REQUIREMENTS

- PIPE SIZE - 4" MIN NON PERFORATED PIPE.
- TYPE OF PIPE - SCH 40 OR SDR 21 NON PERFORATED
- DEPTH OF PIPE - 12" TO TOP OF PIPE FROM FINISH GRADE
- TRACER WIRE - MINIMUM GAUGE #12
COPPERHEAD COPPER CLAD STEEL TRACER WIRE,
GREEN IN COLOR.

NOTE:

CORRECT FITTINGS MUST BE USED WITH ALL PIPE, NO TAPING OR SPLICING WILL BE ACCEPTED. A TRACER WIRE SHALL BE INSTALLED ALONG WITH THE PIPE, THIS WIRE MUST BE COPPERHEAD #12 AWG CCS #1230HS COMPLYING WITH ASTM-D-1248, 30 VOLT RATING BE EXPOSED A MINIMUM LENGTH OF 12 INCHES AT THE HOUSE AND SHALL DEAD END AT THE CONNECTION OR TILE DISCHARGE. NO WIRE SHALL BE ACCEPTED EXCEPT AS SPECIFIED ABOVE.

NOTE:

NOTE: THE TRENCH MUST BE LEFT OPEN AT ALL CONNECTIONS FOR INSPECTION PURPOSES. IF A TILE LINE IS TO DEAD END INTO A POND OR WET LAND A FENCE POST SHALL CLEARLY MARK ITS END. ALL INSPECTIONS SHALL REQUIRE A 24 HOUR NOTICE. ALL TRENCHES MUST BE BACK FILLED WITHIN 24 HOURS. IT IS RECOMMENDED THAT A REPRESENTATIVE OF THE BUILDER BE PRESENT AT ALL INSPECTIONS.



SUMP PUMP DISCHARGE REQUIREMENTS



DATE:
02/2020

STD. DETAIL
4-306 (2 OF 2)

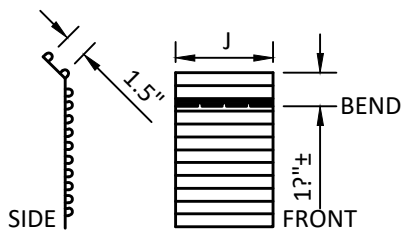

RODENT SHIELD ®

DIMENSIONS ARE APPROXIMATE TO ALLOW FOR BEND AND A SNUG FIT IN SLOT IN HEADWALL

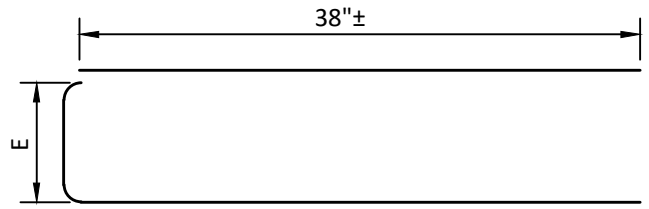
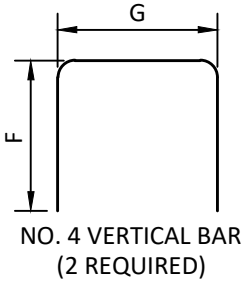

NO. 4 HORIZONTAL BAR

DIMENSION	4" DIA. PIPE	6" DIA. PIPE	8" DIA. PIPE
A	6.5"	8.5"	10.5"
B	12"	14"	16"
C	5"	7"	9"
D	12"	14"	16"
E	8.5"	10.5"	12.5"
F	9"	11"	13"
G	9.5"	11.5"	13.5"
H Δ	5"	7"	9.5"
I	11"	14"	15"
J	5 7/8"	7 7/8"	10"
APPROX. WT.	209 LBS	254 LBS	298 LBS

Δ EXACT DIMENSION DEPENDENT ON COUPLING METHOD.

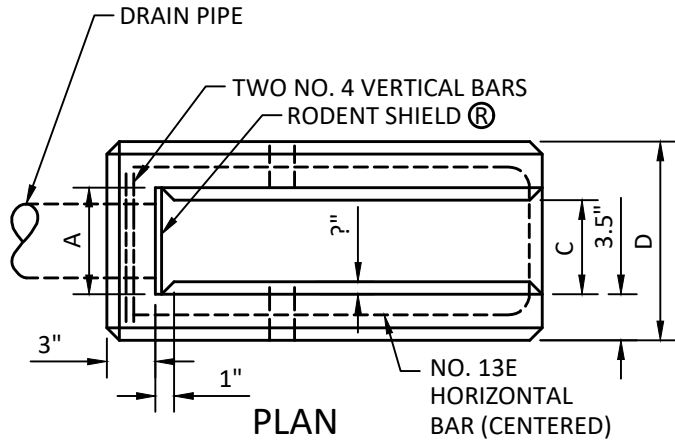

PLAN

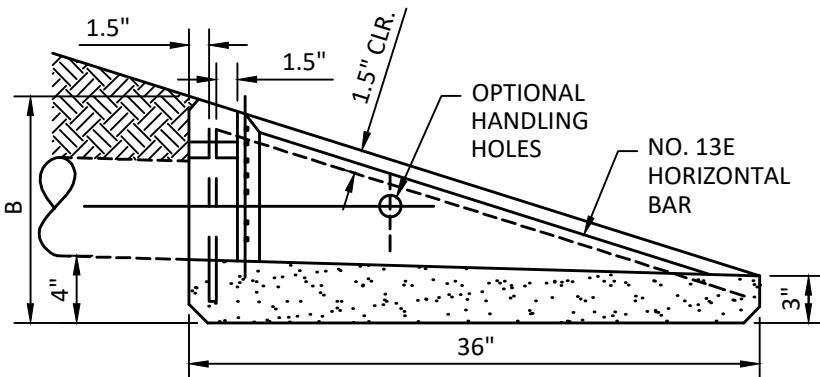

SECTION

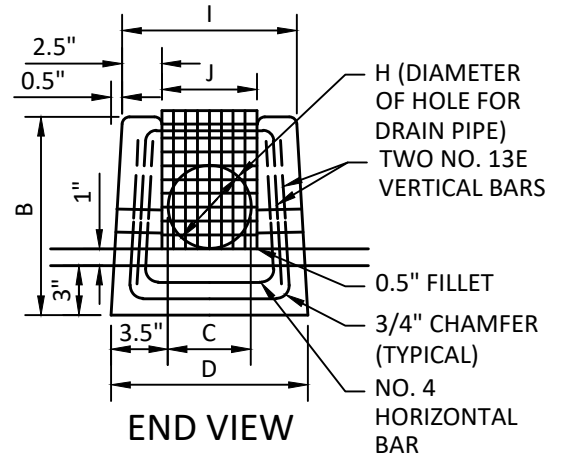

END VIEW

NOTES:

1. CONCRETE FOR THE HEADWALLS SHALL HAVE A MAXIMUM WATER TO CEMENT (W/C) RATIO OF 4.0, AN AIR CONTENT OF APPROXIMATELY 5% AND A COMPRESSIVE STRENGTH OF 34.5 MPA PRIOR TO SHIPPING. THE MAXIMUM AMOUNT OF FLY ASH SUBSTITUTED FOR CEMENT ALLOWED IN THE MIX SHALL BE 15% BY WEIGHT. NO SUBSTANCE OTHER THAN CEMENT, FLY ASH, WATER, AGGREGATE AIR ENTRAINING AGENT AND TYPE A, C, E OR F ADMIXTURES WILL BE ALLOWED IN THE MIX. ALL CONCRETE MATERIALS SHALL MEET THE REQUIREMENTS OF SPEC. 2461. THE EPOXY BARS SHALL BE SECURELY RETAINED SO THEY ARE NOT DISPLACED DURING CONCRETE PLACEMENT. TIE WIRE SHALL BE EPOXY COATED. WELDING WILL NOT BE PERMITTED. THE FABRICATOR SHALL PROVIDE A QUALITY CONTROL PROGRAM APPROVED BY THE MATERIALS ENGINEER.
2. THE RODENT SHIELD SHALL BE FABRICATED FROM CARBON STEEL FLATTENED EXPANDED METAL, STYLE 13 MM NO. 13F. IT SHALL BE HOT DIPPED GALVANIZED AFTER FABRICATION. ACTUAL SCREEN DIMENSIONS SHALL BE SUCH AS WILL SNUGLY FIT THE PROVIDED SLOT (TAPERED IF NECESSARY), WITH THE SCREEN LIP FITTING FLUSH WITH THE CASTING TOP AND THE BOTTOM FITTING TIGHT TO THE FLOW LINE.



**PRECAST CONCRETE
HEADWALL FOR
SUBSURFACE DRAINS**



DATE:
02/2020

STD. DETAIL
4-307

TIE LAST 3 PIPE JOINTS,
USE 2 TIE BOLT FASTENERS
PER JOINT, INSTALL AT 60°
FROM TOP OR BOTTOM OF PIPE

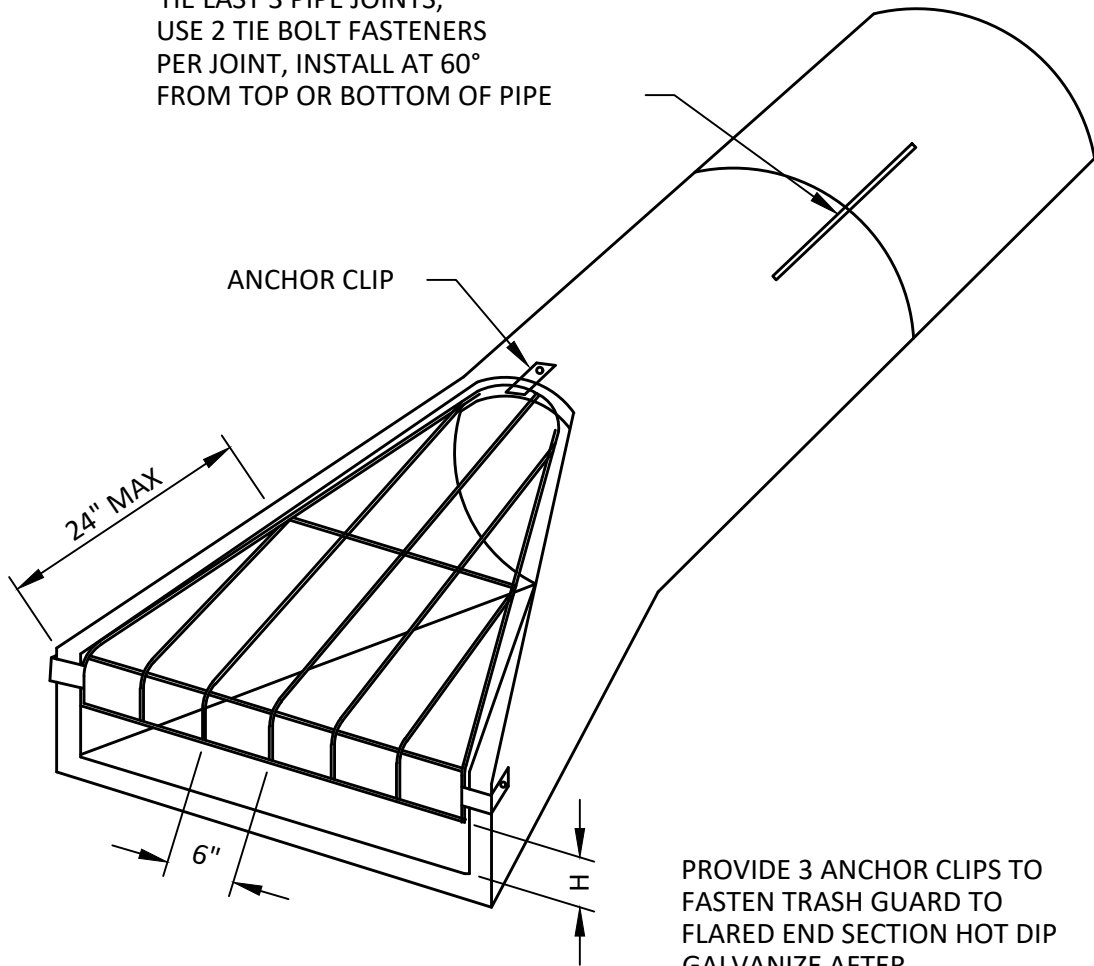

ANCHOR BOTH SIDES

PROVIDE 3 ANCHOR CLIPS TO
FASTEN TRASH GUARD TO
FLARED END SECTION HOT DIP
GALVANIZE AFTER
FABRICATION

TRASH GUARD SIZES			
PIPE SIZE	BARS	"H"	BOLTS
12"-18"	3/4"Ø	4"	5/8"
21"-42"	1"Ø	6"	3/4"
42"-72"	1 1/4"Ø	12"	1"

RC APRON TRASH RACK

NOT TO SCALE

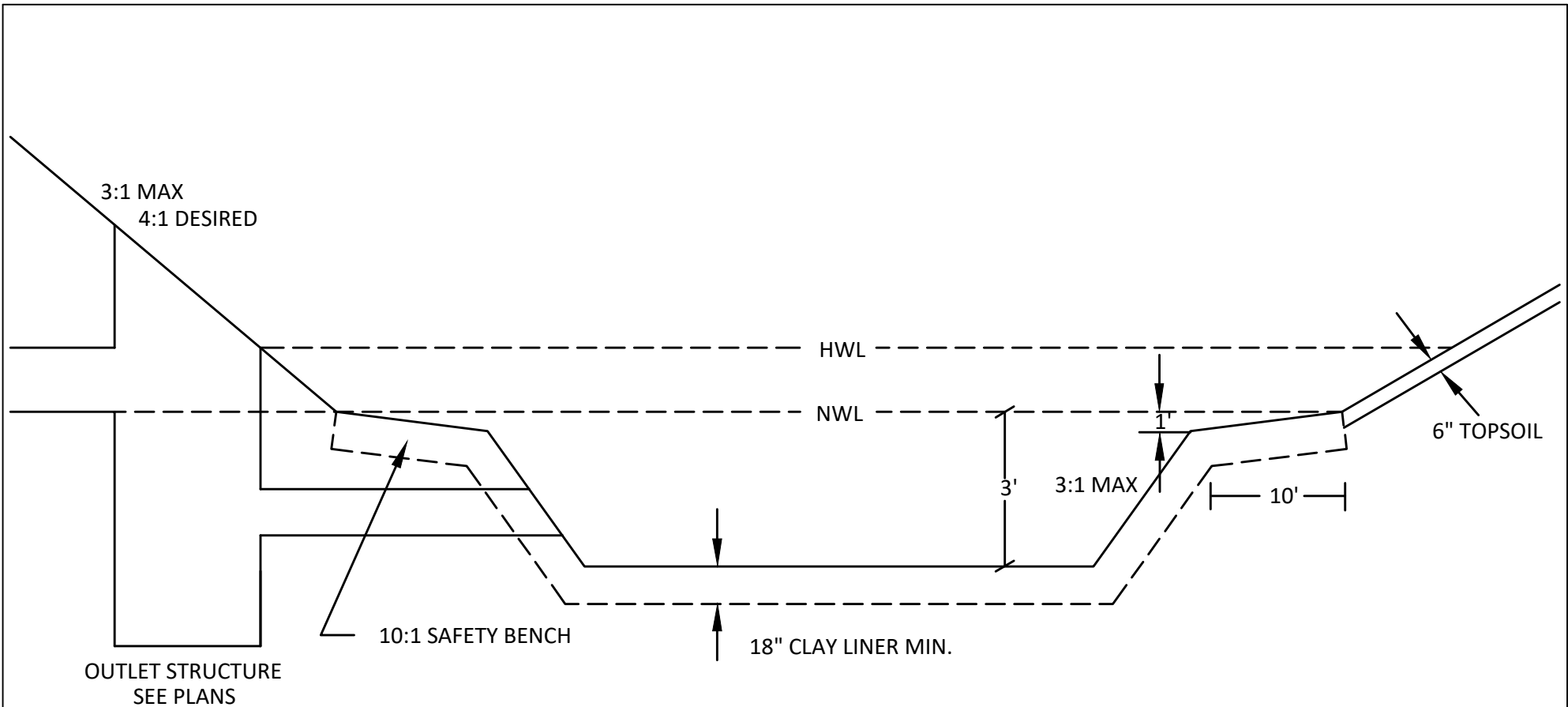

NOTE: PLANT POND SLOPES
WITH WILDFLOWER MIX TO BE
APPROVED BY ENGINEER

POND DETAIL

NOT TO SCALE



POND DETAIL



DATE:
02/2020

STD. DETAIL
4-800

NEENAH 1642 FRAME WITH SELF SEAL LID
LETTERED "SANITARY SEWER" WITH TWO
CONCEALED PICKHOLES AND NO LUG

- ① RUBBER GASKET (TYP)
- ② FLEXIBLE WATERTIGHT SEAL TO BE APPROVED BY ENGINEER
- ③ SHAPE, DEPTH AND SLOPE OF INVERT TO BE APPROVED BY ENGINEER
- ④ STEEL REINFORCED PLASTIC STEPS SHALL BE A POLYPROPYLENE PLASTIC REINFORCED WITH A NO 2 DEFORMED STEEL ROD GRADE 60
- ⑤ MnDOT TYPE "B" ECCENTRIC PRECAST CONCRETE CONE SECTION TYPICAL FOR ALL MANHOLES
- ⑥ PLACE INTERIOR CHIMNEY SEAL (STRIKE I & I BARRIER WITH DRIP EDGE)
- ⑦ PLACE EXTERIOR JOINT SEAL (WITHIN 2 FEET OF WATER TABLE)
- ⑧ ALL CONNECTIONS TO EXISTING MANHOLE WILL BE CORE CUT WITH GASKET. NO JACK HAMMER ALLOWED.

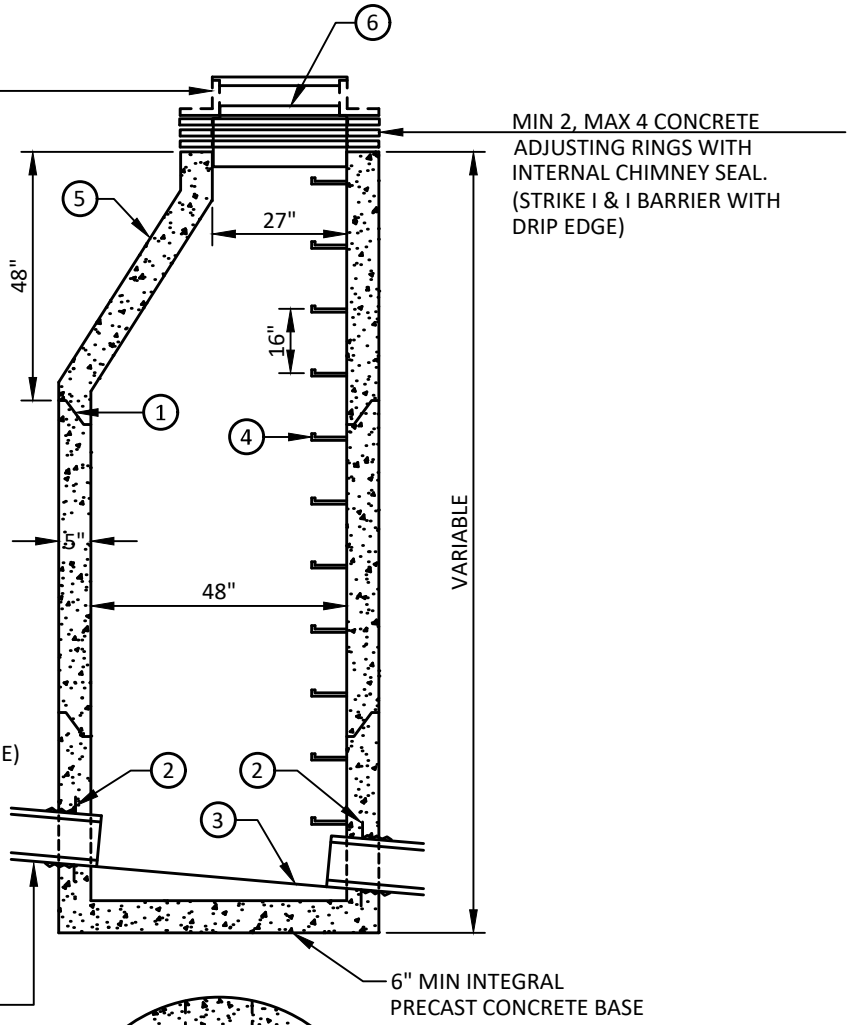

REFER TO PLANS FOR PIPE REQUIRED

CURVE INVERT IN DOWNSTREAM DIRECTION

REFER TO PLANS FOR PIPE REQUIRED

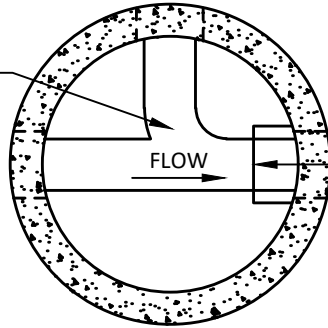

PLAN VIEW

SANITARY MANHOLE
NOT TO SCALE

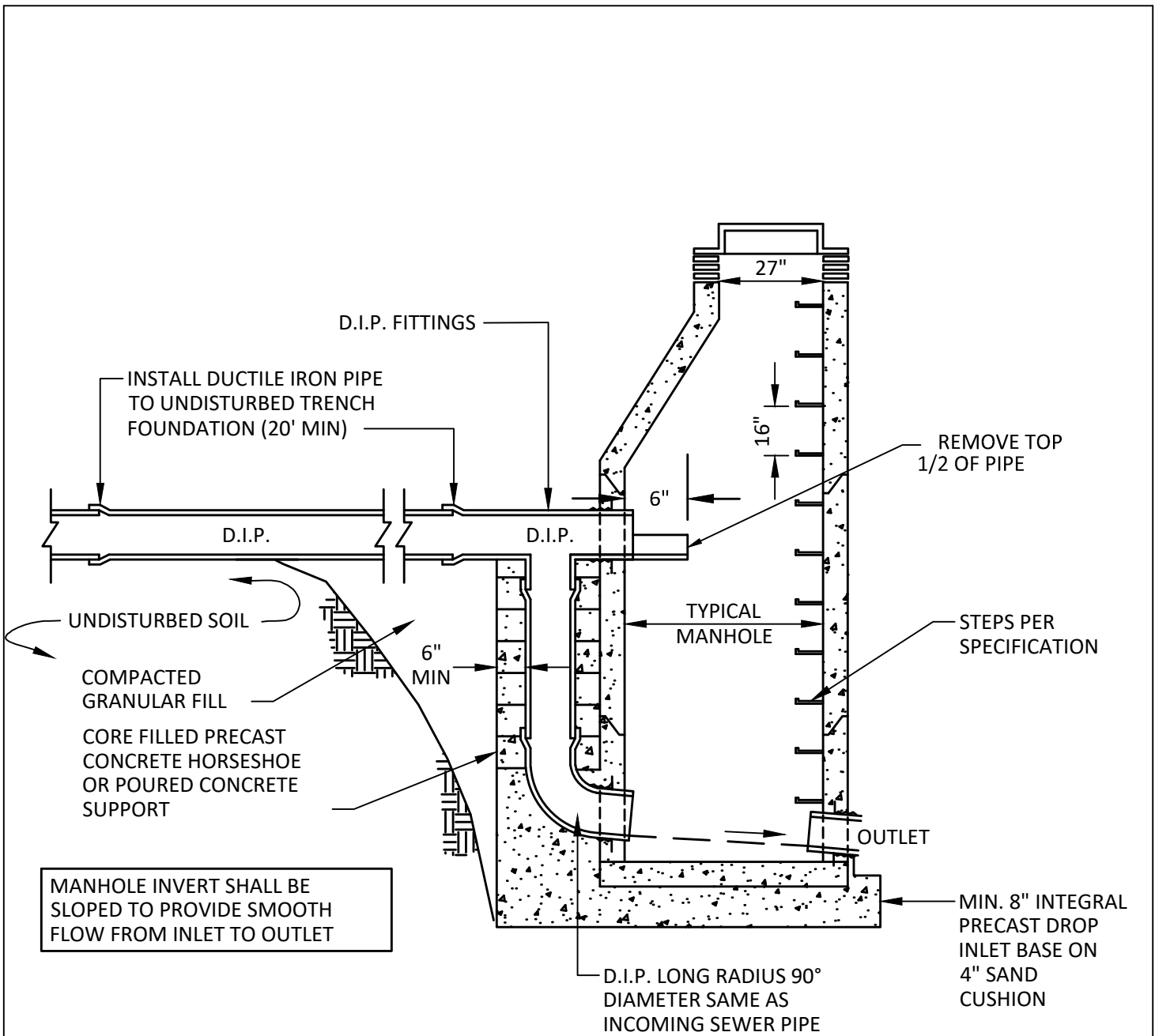

SANITARY MANHOLE WITH OUTSIDE DROP

NOT TO SCALE

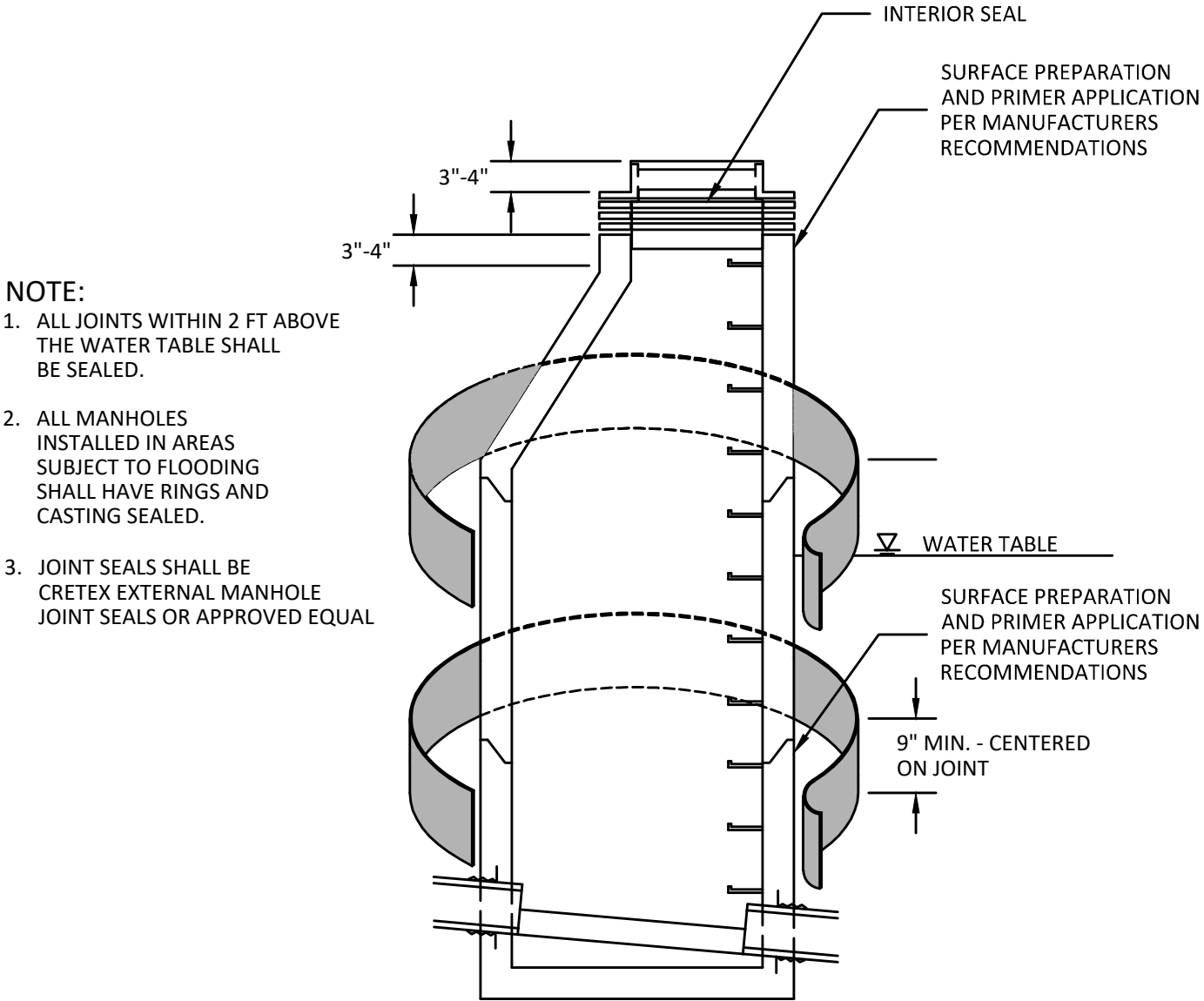

SANITARY SEWER EXTERIOR JOINT SEAL

NOT TO SCALE

PAVING RING
(ONE PIECE)

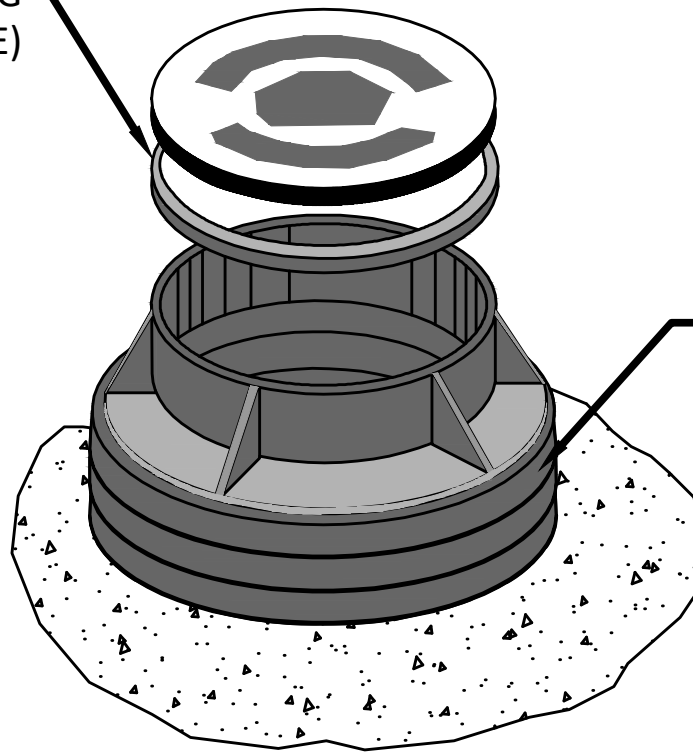

CONCRETE
GRADE RINGS

NOTE: A FIVE HUNDRED DOLLAR (\$500) PENALTY WILL BE ENFORCED FOR EACH CASTING NOT PROPERLY ADJUSTED REQUIRING A PATCH IN THE BITUMINOUS WEARING COURSE.

CASTING AND GRADE ADJUSTMENT RING DETAIL

NOT TO SCALE



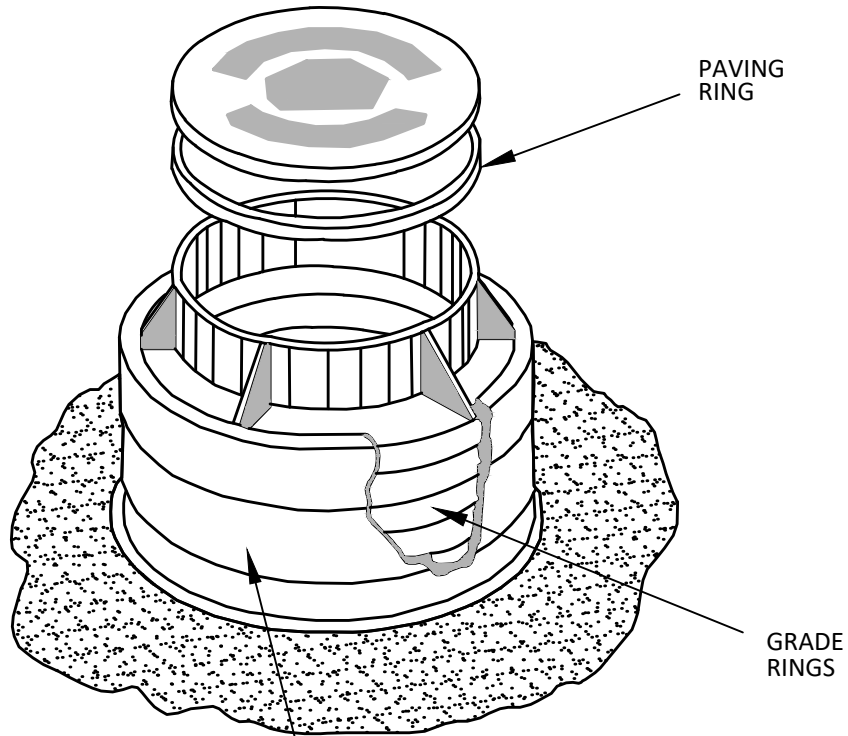

ONE PIECE MOLDED SEAL.
 INFI-SHIELD UNI-BAND EXTERNAL RUBBER
 FRAME SEAL AS MANUFACTURED BY SEALING
 SYSTEMS, INC. OR APPROVED EQUAL.

CASTING AND GRADE ADJUSTMENT
RING EXTERIOR SEAL

NOT TO SCALE

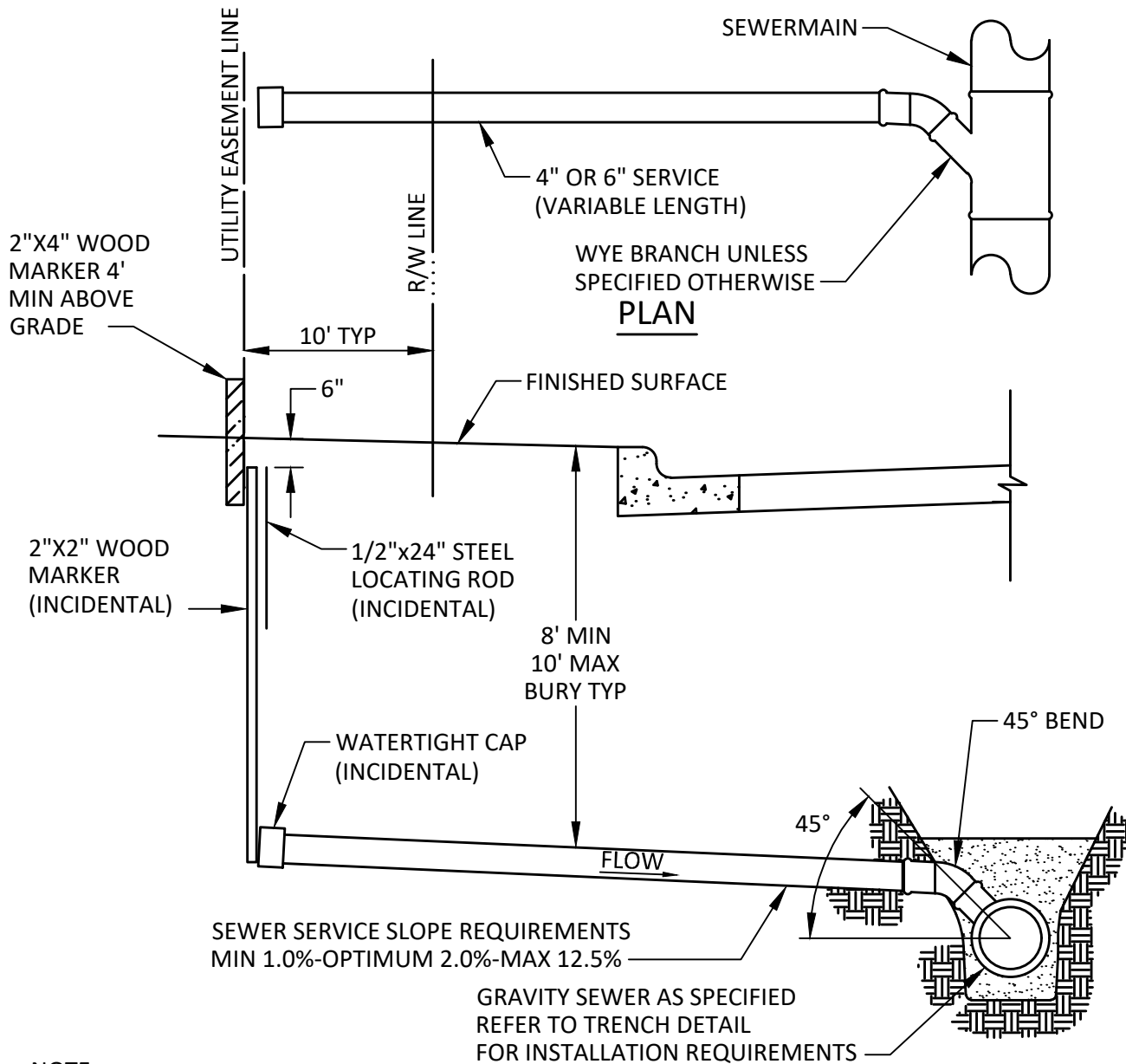

NOTE:
WYES, BENDS AND PIPE SIZES
AS REQUIRED BY PLANS AND SPECS

PROFILE

PIPE MATERIAL SDR 26

SANITARY SEWER SERVICE

NOT TO SCALE



SANITARY SEWER
SERVICE



DATE:
02/2020

STD. DETAIL
5-101

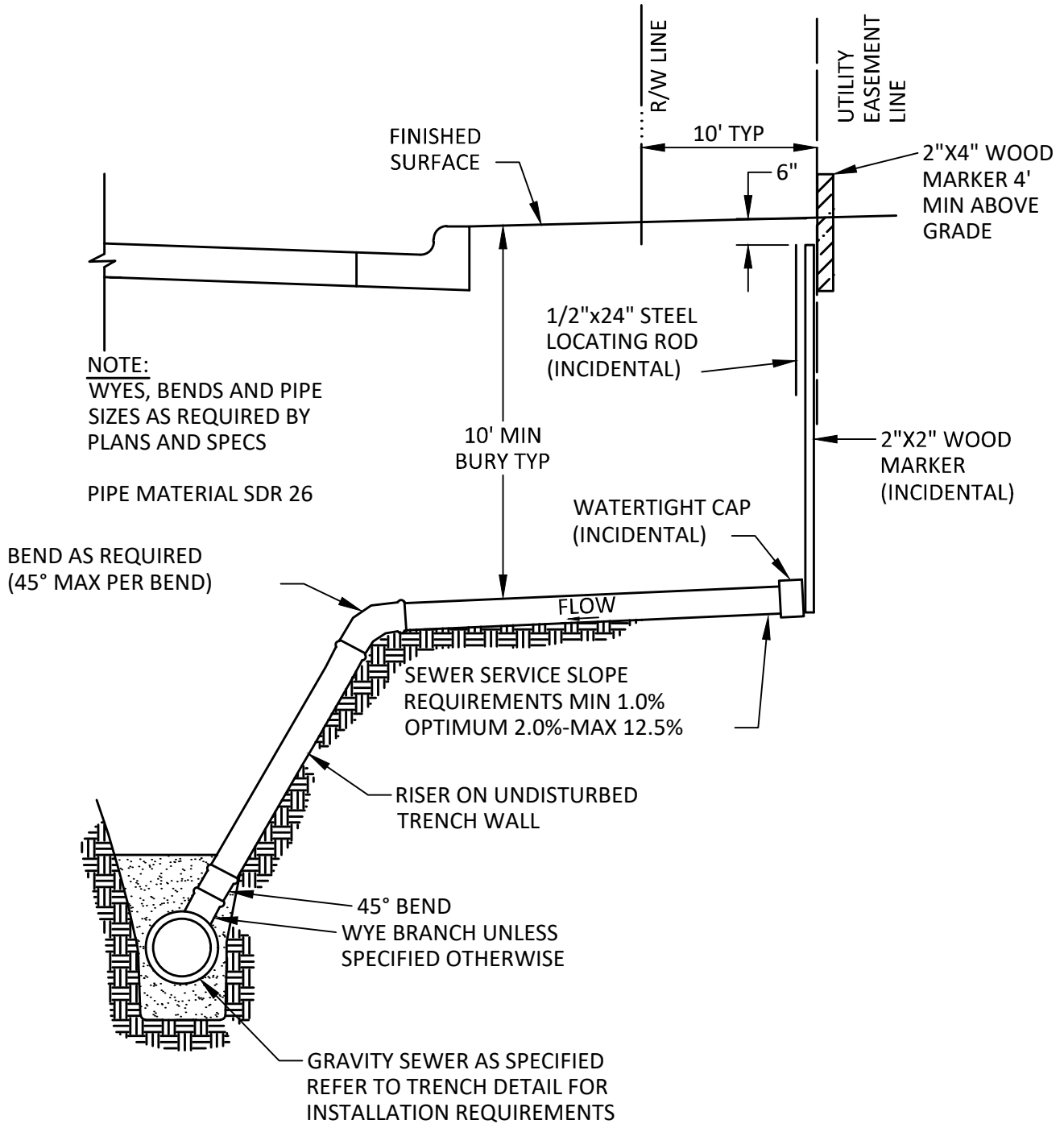

SANITARY SEWER SERVICE RISER

NOT TO SCALE



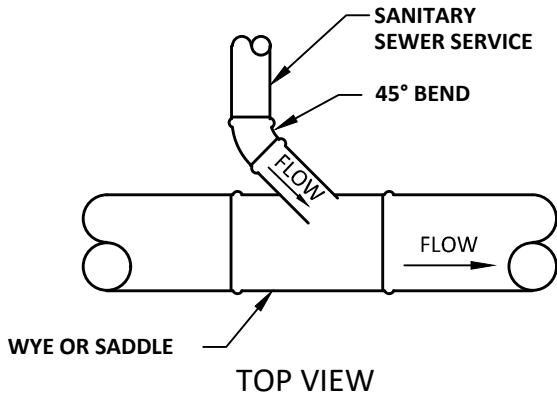

NOTE:
 WYES, BENDS AND PIPE SIZES
 AS REQUIRED BY PLANS AND SPECS

PIPE MATERIAL SDR 26

SEWER SERVICE REQUIREMENTS
 -GRADES-
 MINIMUM - 1.0% (1/8" PER FT)
 OPTIMUM - 2.0% (1/4" PER FT)
 MAXIMUM - 12.5%

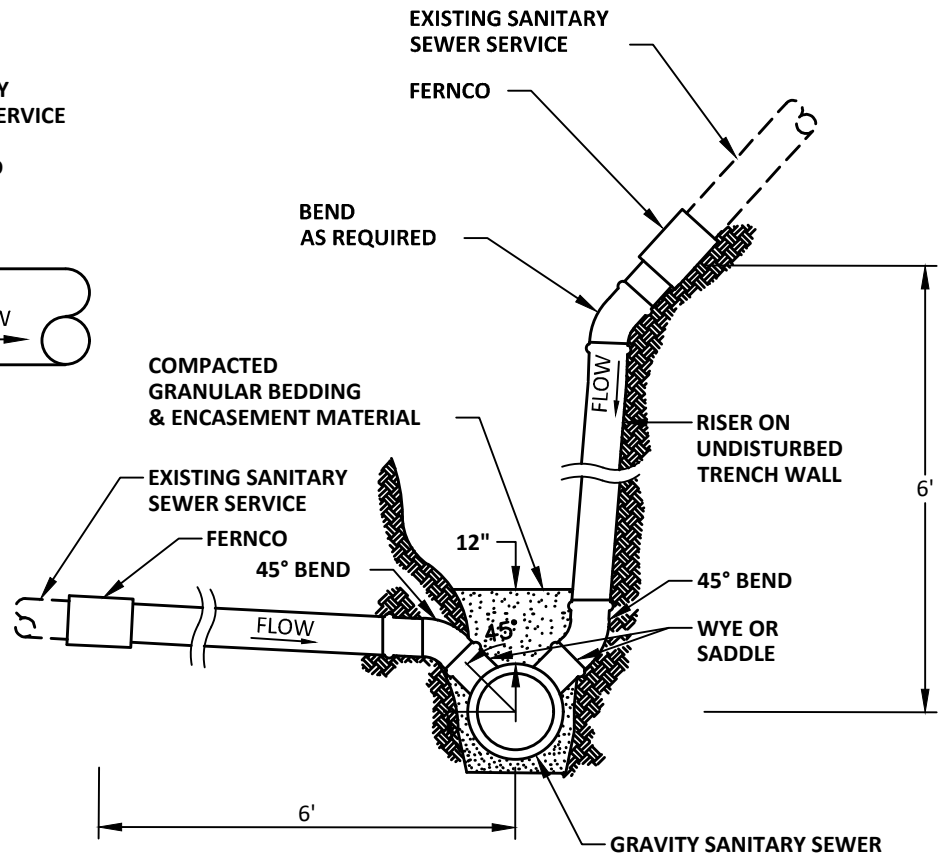

NOTE:
 WHERE NO EXISTING SEWER IS IN PLACE, INSTALL PVC CAP AND MARK
 LOCATION WITH 4"X4"X6' TIMBER & 3/8" X 4' STEEL ROD BURY 6"
 BELOW FINISHED GRADE.

SANITARY SEWER SERVICE AND SERVICE RISER, RECONSTRUCTION

NOT TO SCALE



SANITARY SEWER
 SERVICE AND
 SERVICE RISER,
 RECONSTRUCTION



DATE:
 02/2020

STD. DETAIL
 5-107

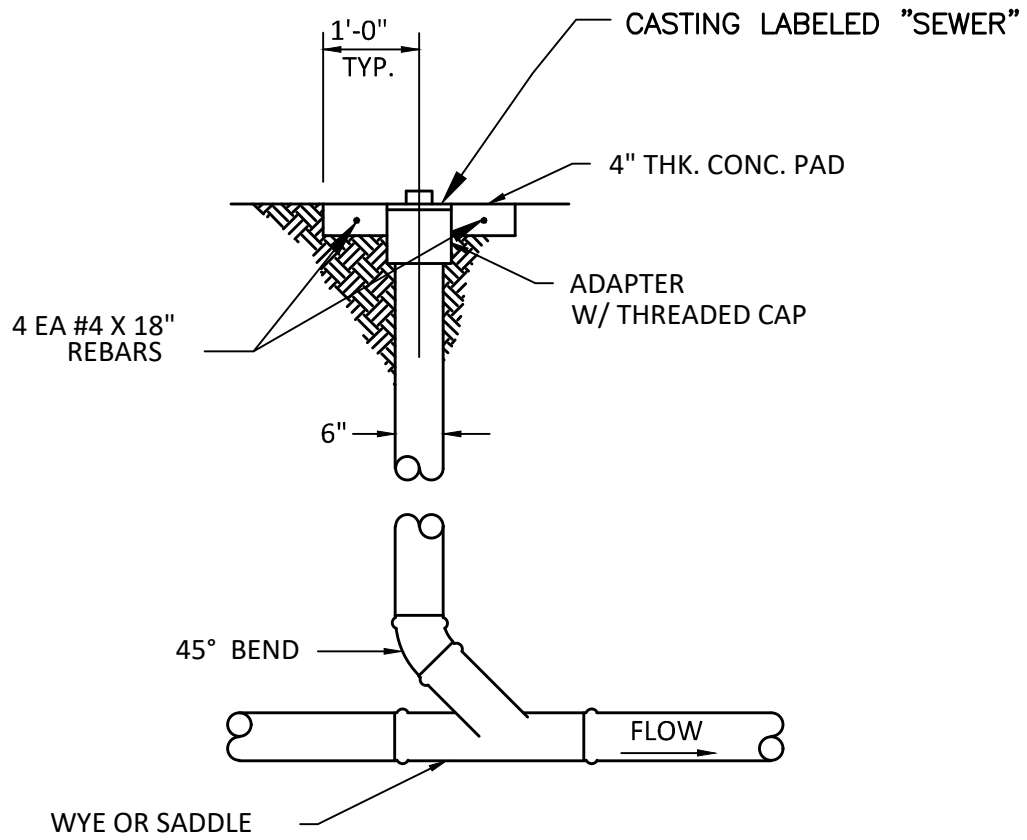

SANITARY SEWER CLEANOUT
NOT TO SCALE

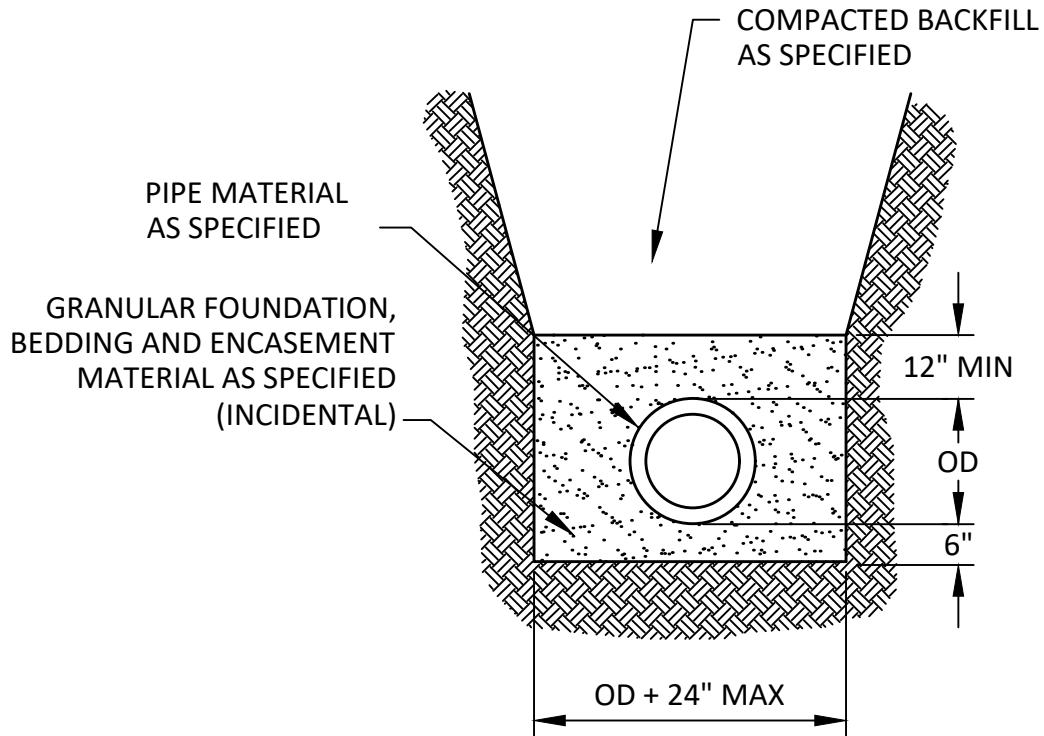

PVC SANITARY SEWER TRENCH
 NOT TO SCALE

4" POLYSTYRENE, STAGGER JOINTS MIN. OF 6"

COMPACTED BACKFILL AS SPECIFIED

PIPE MATERIAL AS SPECIFIED

GRANULAR BEDDING & ENCASEMENT MATERIAL AS SPECIFIED - INCIDENTAL TO SEWER CONSTRUCTION

COPPERHEAD #12 PART #1230 G-HS LOCATOR WIRE BRING WIRE TO SURFACE AT EACH VALVE OR HYDRANT OR 1000 FEET, WHICHEVER IS LESS (SEE SPECIFICATIONS)

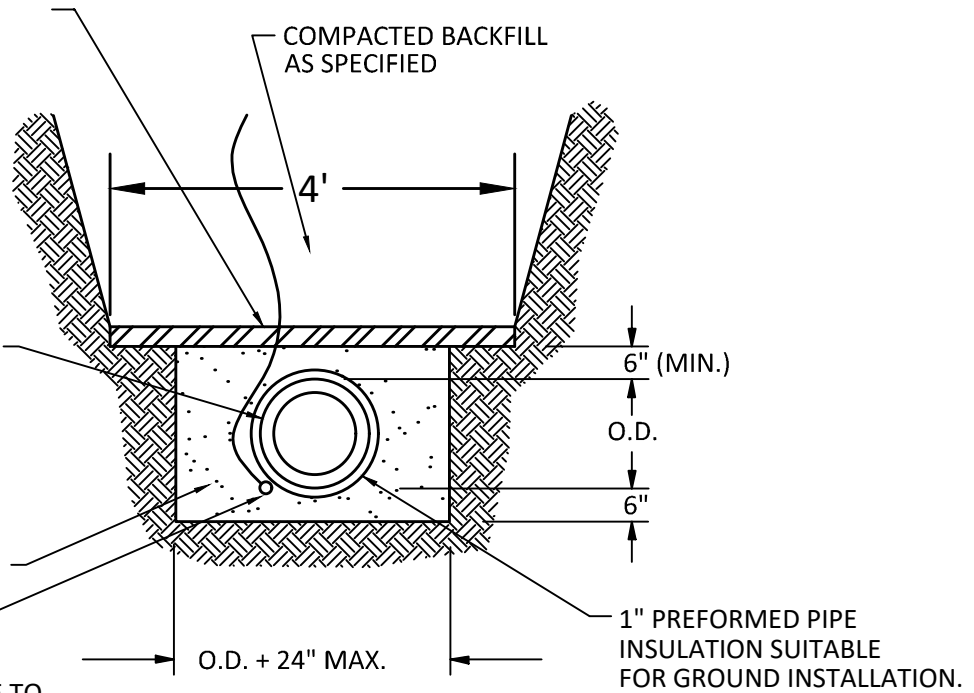

NOTE: IF SERVICE LINE HAS LESS THAN 7' OF COVER INSULATION WIDTH SHALL INCREASE AS FOLLOWS:

DEPTH OF COVER	WIDTH OF INSULATION
6 FT.	6 FT.
5 FT.	8 FT.
4 FT.	10 FT.

INSULATION DETAIL SANITARY SEWER

NOT TO SCALE

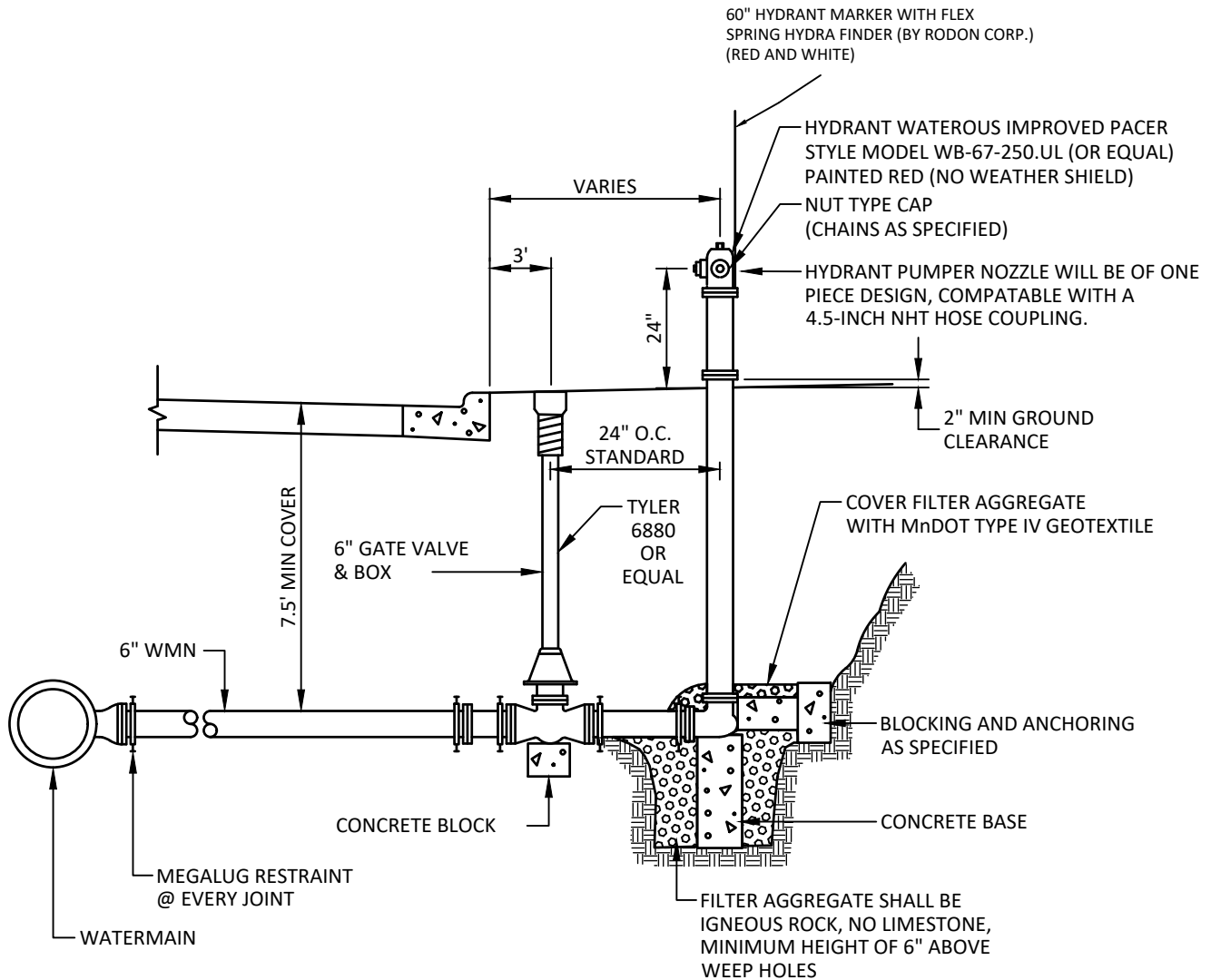

HYDRANTS LOCATED WHERE THE GROUNDWATER TABLE IS ABOVE THE DRAIN OUTLET SHALL HAVE THE OUTLET DRAIN PLUGGED AND SHALL BE EQUIPPED WITH A TAG STATING "PUMP AFTER USE." PUMPER NOZZLE SHALL BE PAINTED BLACK.

HYDRANT
NOT TO SCALE

78" STAINLESS STEEL
STATIONARY ROD
FOR 1" OR EQUAL

FORD EM2-80-56-75R CURB
BOX FOR 1" OR EQUAL

FORD B22-444M CURB STOP
FOR 1" OR EQUAL

6' STEEL T POST MARKER
PAINT UPPER 12" BLUE
(INCIDENTAL)

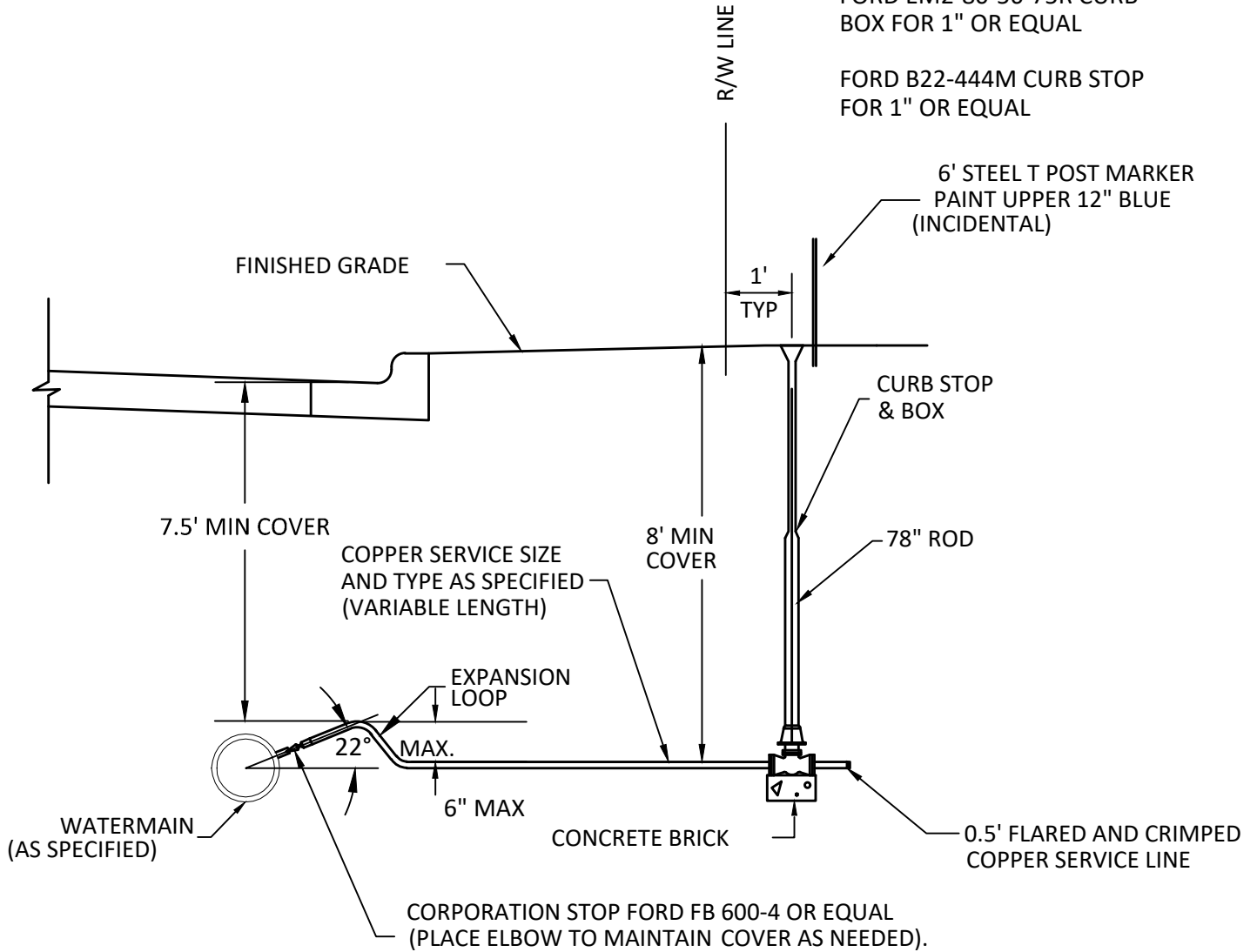

WATER SERVICE INSTALLATION
NOT TO SCALE



WATER SERVICE
INSTALLATION



DATE:
02/2020

STD. DETAIL
6-101A

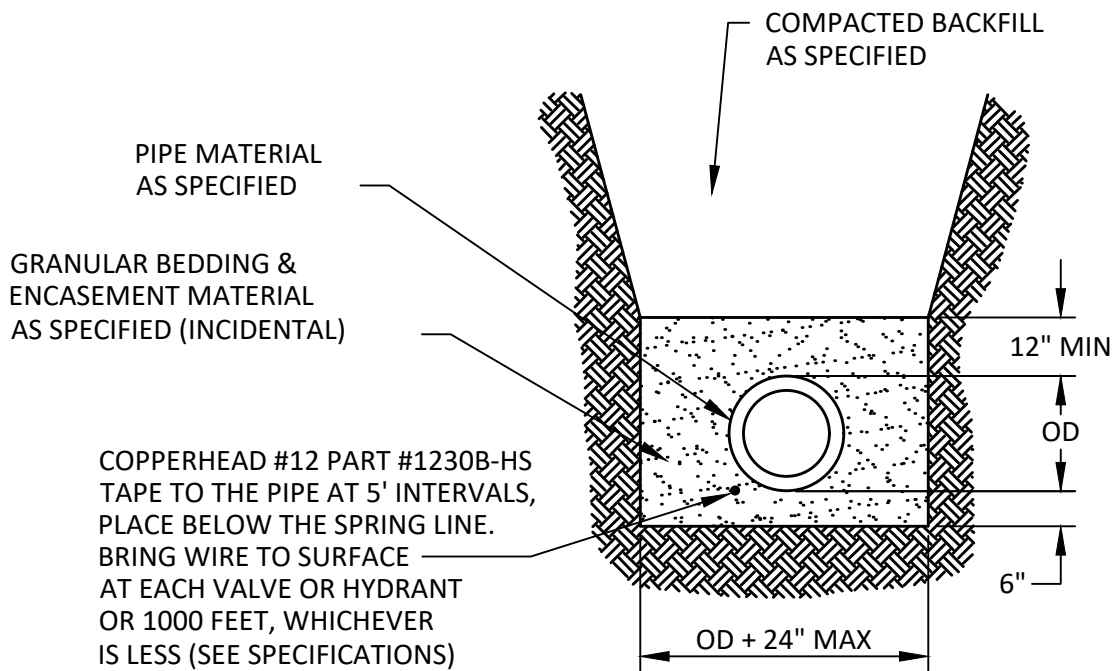

PVC WATERMAIN TRENCH
NOT TO SCALE

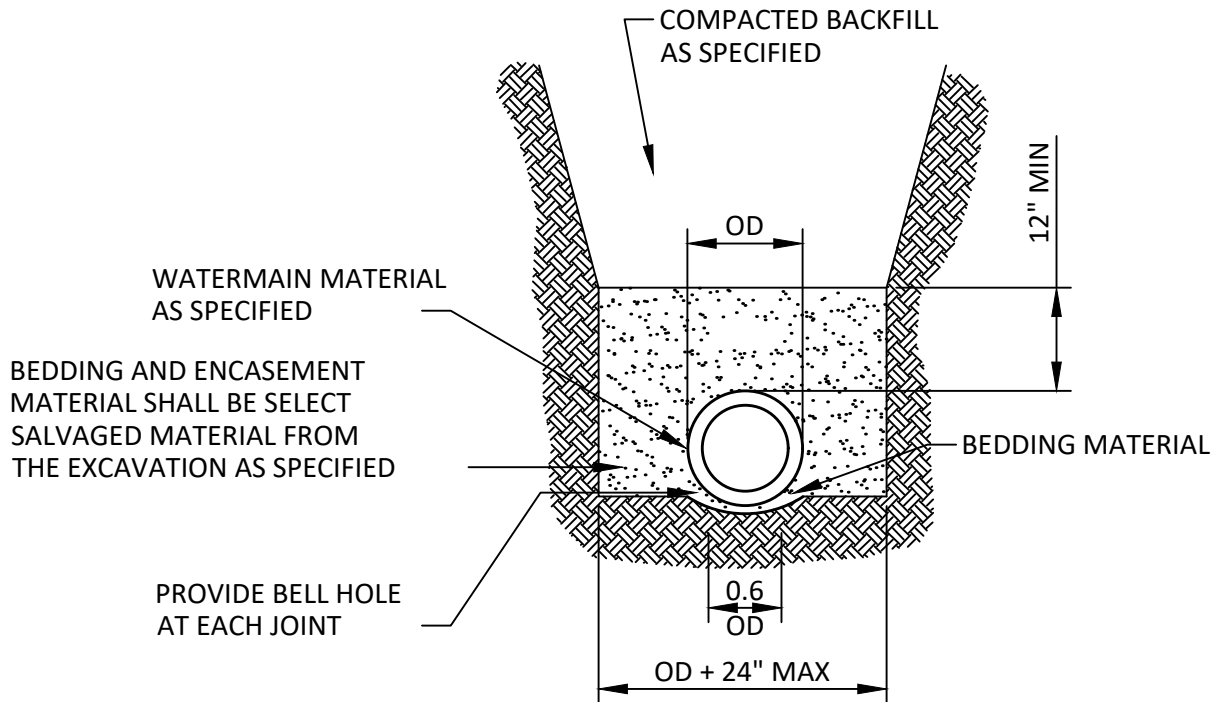

DIP WATERMAIN
TRENCH
 NOT TO SCALE

4" POLYSTYRENE, MIN 35 PSI
COMPRESSIVE STRENGTH,
STAGGER JOINTS MIN. OF 6"

COMPACTED BACKFILL
AS SPECIFIED

PIPE MATERIAL
AS SPECIFIED

GRANULAR BEDDING &
ENCASEMENT MATERIAL AS
SPECIFIED - INCIDENTAL TO
WATERMAIN CONSTRUCTION

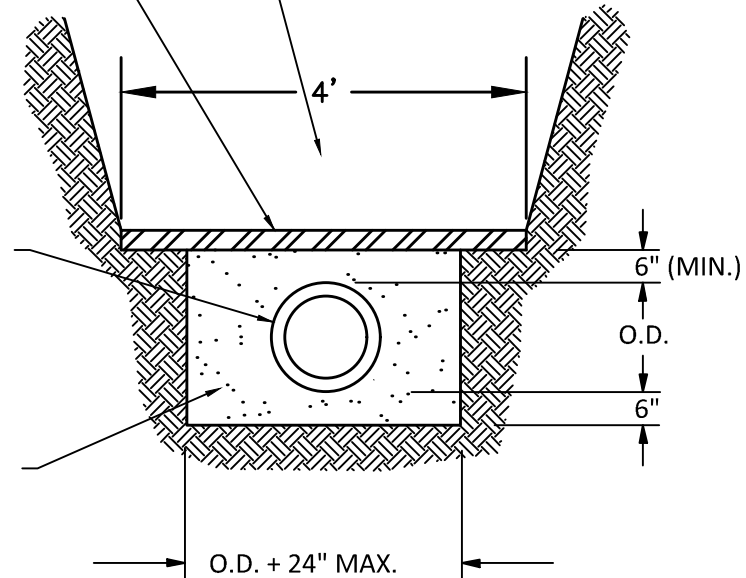

NOTE: IF WATER LINE HAS LESS THAN 7.5' OF COVER
INSULATION WIDTH SHALL INCREASE AS FOLLOWS:

<u>DEPTH OF COVER</u>	<u>WIDTH OF INSULATION</u>
7.4-6.5 FT.	4 FT.
6.5-4.0 FT.	6 FT.
3 FT.	8 FT.
2 FT.	10 FT.

WATERMAIN INSULATION

NOT TO SCALE

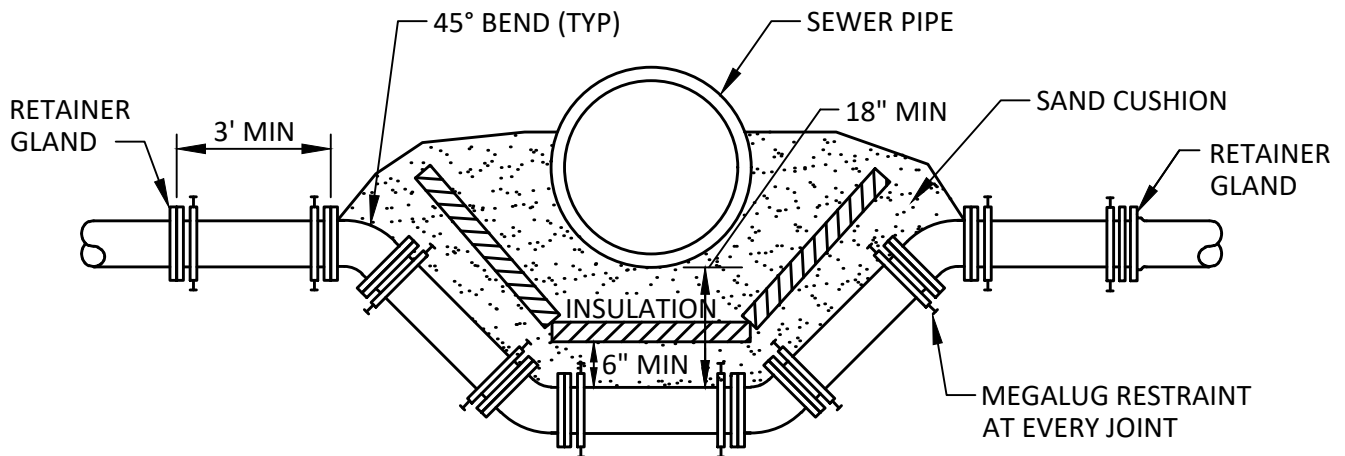

NOTES:

1. PROVIDE MEGALUG RESTRAINT AT JOINT ON BENDS AND AS SHOWN THIS DETAIL
2. COAT ALL ANCHORAGE AS PER SPECS
3. PROVIDE SAND CUSHION BETWEEN TOP OF WATERMAIN AND BOTTOM OF SEWER PIPE, MIN DIMENSIONS AS SHOWN THIS DETAIL (INCIDENTAL)
4. INSULATION TO BE 4" THICK POLYSTYRENE
5. IN AREAS OF GREATER LONGITUDINAL SPACE, THE WATERMAIN SHALL BE GRADUALLY LOWERED AND RAISED, USING NO BENDS, OVER A DISTANCE OF 200'.

WATERMAIN OFFSET

NOT TO SCALE

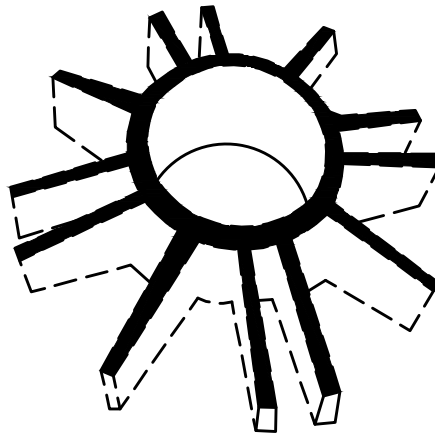

PHOENIX PLASTIC CASING SPACER
OR APPROVED EQUAL

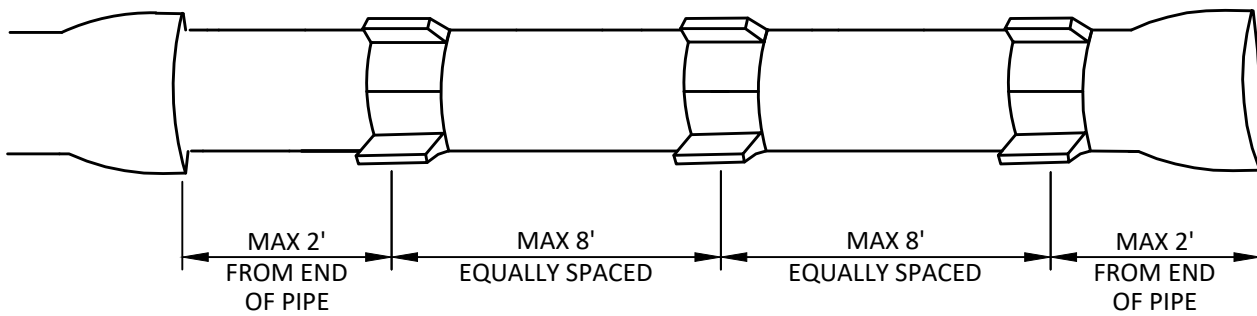
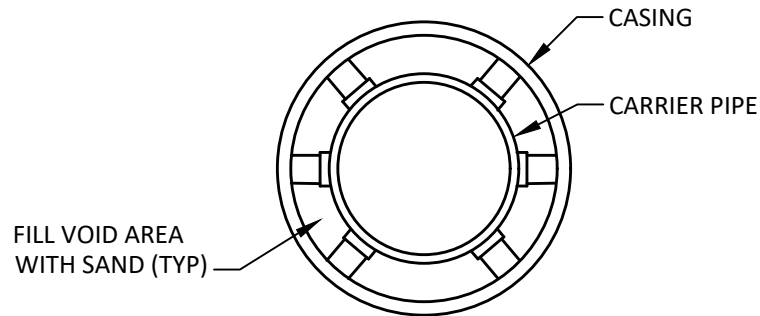

WATERMAIN PIPE SUPPORT
IN CASING, PLASTIC SPACERS
NOT TO SCALE

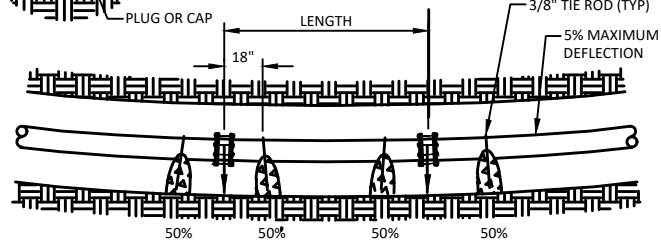
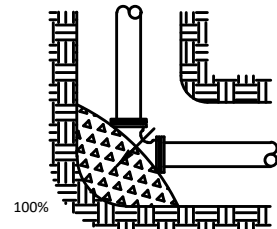
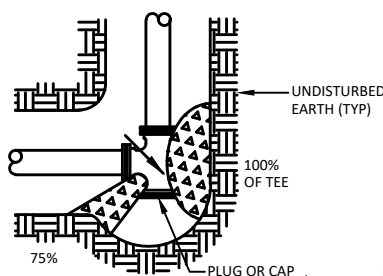
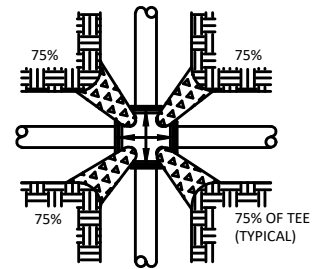
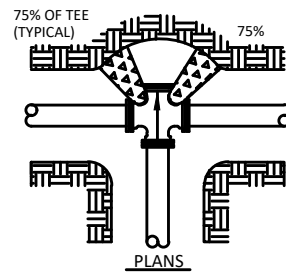
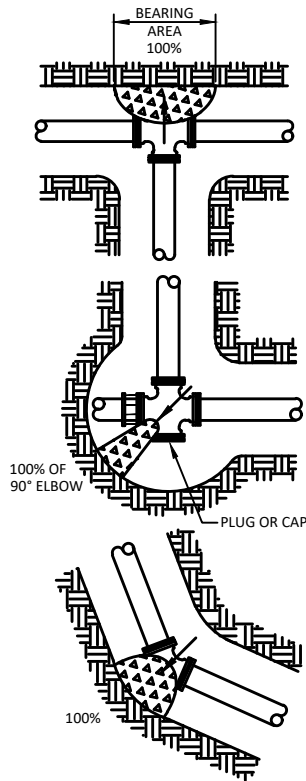

CURVE THRUST BLOCKING

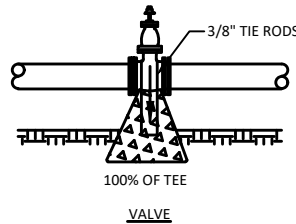
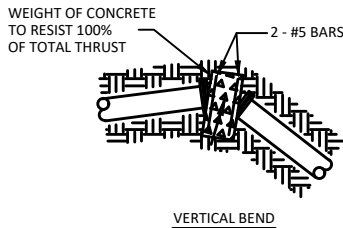

VALVE

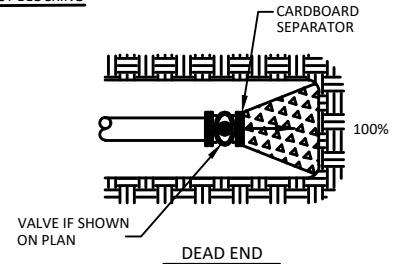

DEAD END

ARROWS (→) INDICATE THRUST DIRECTION

NOTES:

- FIGURE (100%) AT THRUST BLOCK INDICATES PER CENT OF TOTAL THRUST TO BE APPLIED FOR BEARING AREA.
- CONCRETE FOR THRUST BLOCKS TO BE 2000 PSI.
- RESTRAINING RODS ARE REQUIRED AT ALL TEES AND AT BENDS DEFLECTING 22-1/2" OR MORE.
- WRAP THE PIPE WITH POLYETHYLENE WRAPPING PRIOR TO POURING THE THRUST BLOCK.
- SEE SOILS REPORT FOR BEARING STRENGTH OF SOIL. IN ABSENCE OF A SOILS REPORT, AN AVERAGE SOIL (SPADABLE MEDIUM CLAY) CAN BE ASSUMED TO HAVE A BEARING STRENGTH OF 2000 PSI.
- THRUST BLOCKS ARE NOT REQUIRED ON PVC WITH SOLVENT WELDED JOINTS.

SIDE THRUST PER 100 LB/SQ IN PRESSURE PER DEGREE OF DEFLECTION

PIPE SIZE	SIDE THRUST-LB	PIPE SIZE	SIDE THRUST-LB
4	35	14	377
6	72	16	486
8	122	18	665
10	197	20	790
12	278	24	1150

MULTIPLY THRUST BY DEGREE OF DEFLECTION TO OBTAIN TOTAL THRUST

100% BEARING AREA (SQ FT)

PIPE SIZE	DEAD END OR TEE	90° ELBOW	45° ELBOW	22 1/2° ELBOW
4	2.4	3.4	1.9	0.9
6	4.9	6.9	3.8	1.9
8	8.4	11.8	6.4	3.4
10	13.7	19.3	10.5	5.4
12	19.4	27.3	14.9	7.7
14	26.3	37.0	20.1	10.3
16	34.0	47.9	26.2	13.3
18	43.9	61.8	33.7	17.2
20	54.3	76.4	41.7	21.2
24	77.9	109.8	59.8	30.5

NOTE:
BEARING AREAS ARE BASED ON 250 LB MAXIMUM PRESSURE AND SOIL BEARING STRENGTH OF 2000 LB/SQ FT.

CONCRETE THRUST BLOCKS
NOT TO SCALE



CONCRETE THRUST BLOCKS



DATE:
02/2020

STD. DETAIL
6-205

NOTES:

1. SHAPE OF BACK OF BUTTRESS MAY VARY AS LONG AS POURED AGAINST FIRM UNDISTURBED EARTH.
2. DIMENSION C1,C2,C3 SHOULD BE LARGE ENOUGH TO MAKE ANGLE EQUAL TO OR LARGER THAN 45°.
3. DIMENSION A1,A2,A3 SHOULD BE AS LARGE AS POSSIBLE WITHOUT INTERFERING WITH MJ BOLTS.
4. = 45° MINIMUM.
5. PLACE POLYETHYLENE BETWEEN CONCRETE & PIPE.

BUTTRESS DIMENSIONS						
PIPE SIZE	22 1/2° BEND		45° BEND		90° BEND	
	B1	D1	B 2	D2	B 3	D3
6"	1'-5"	1'-5"	1'-5"	1'-5"	2'-1"	1'-6"
8"	1'-5"	1'-5"	2'-1"	1'-6"	2'-8"	2'-0"
12"	1'-10"	1'-10"	3'-4"	2'-0"	4'-9"	2'-6"
16"	3'-0"	2'-0"	3'-10"	3'-0"	6'-2"	3'-6"
20"	3'-6"	2'-8"	5'-6"	3'-4"	8'-4"	4'-0"
24"	4'-4"	3'-0"	6'-10"	3'-10"	9'-8"	5'-0"
30"	-	-	9'-3"	6'-0"	17'-0"	6'-0"

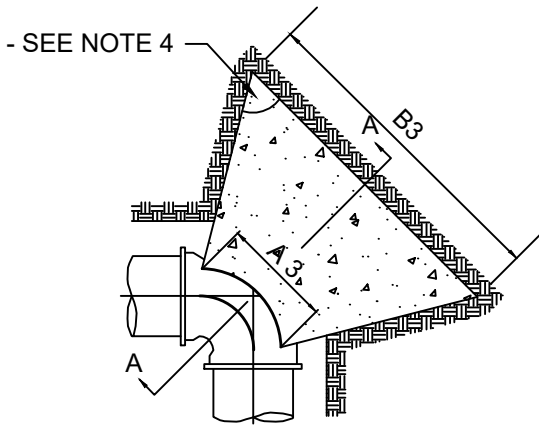

PLAN 90° BENDS

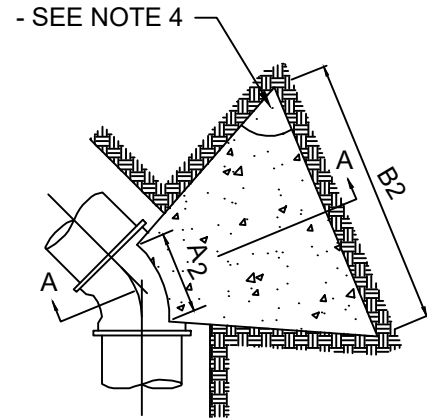

PLAN 45° BENDS

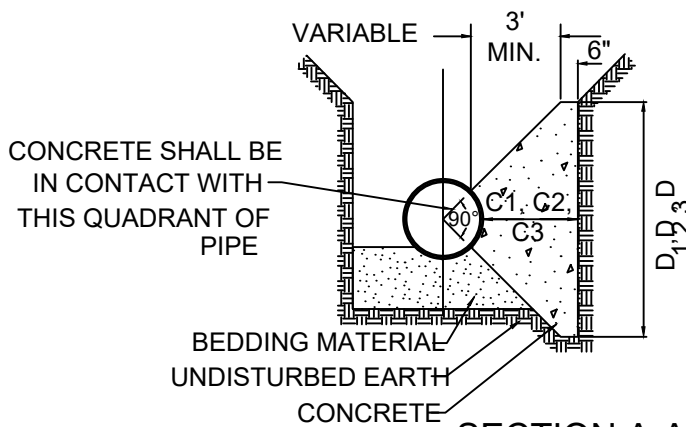

SECTION A-A

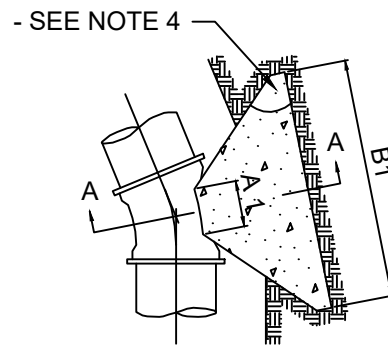

PLAN 22 1/2° BENDS

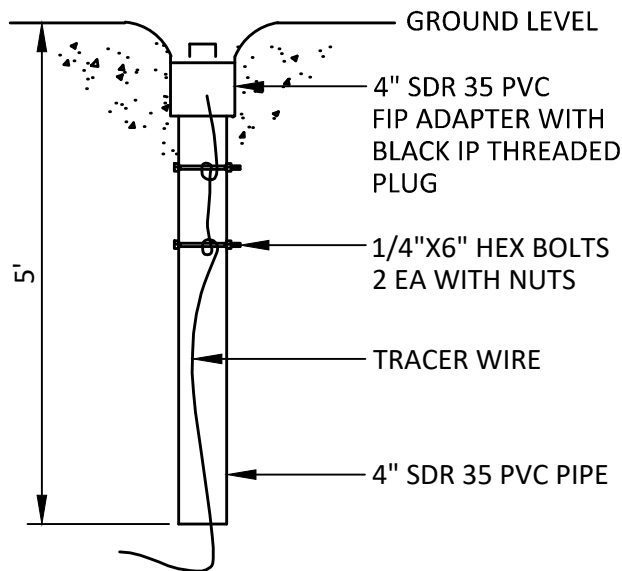

**TRACER WIRE PEDESTAL,
PVC PIPE**
NOT TO SCALE

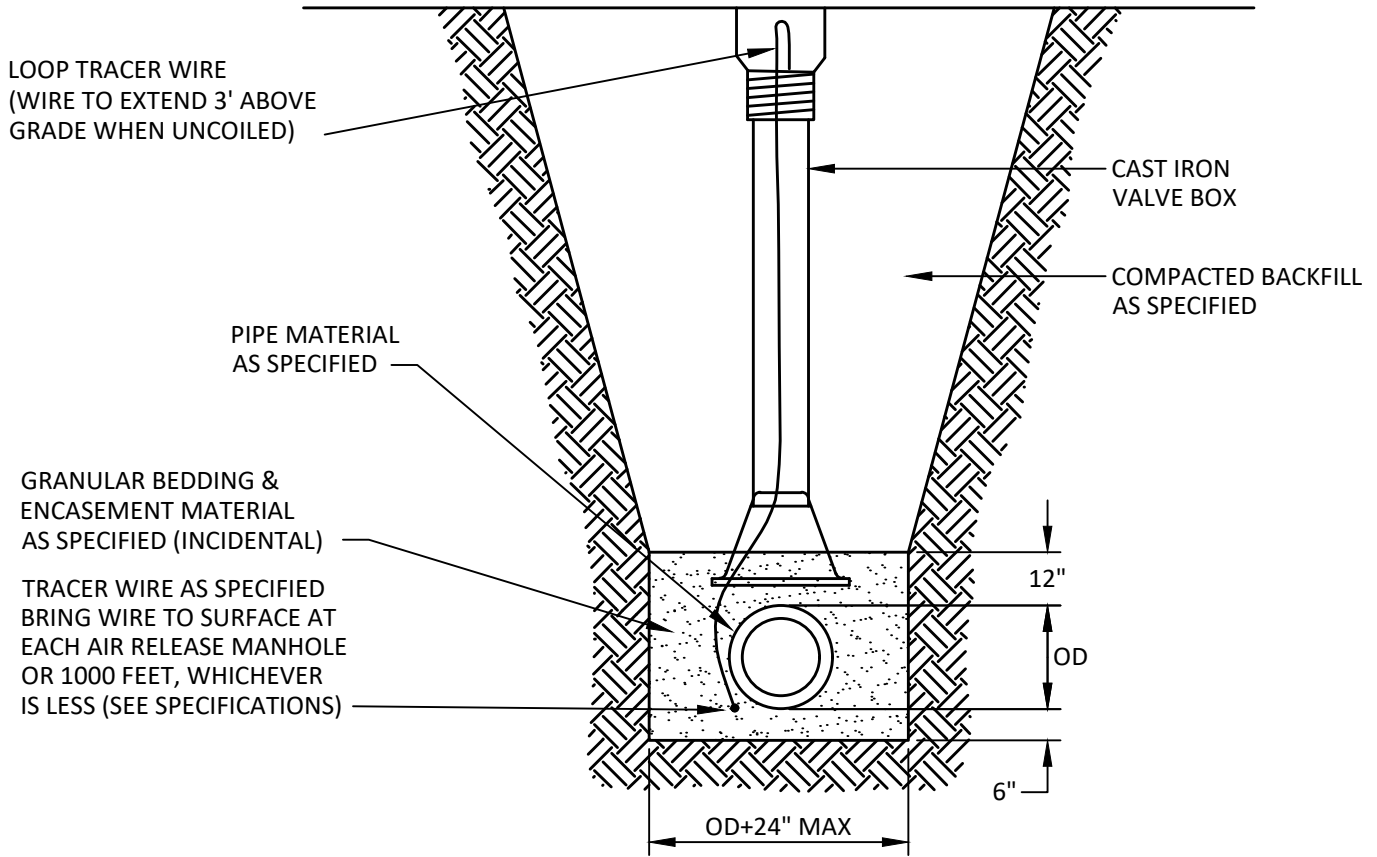

**TRACER WIRE PEDESTAL
VALVE BOX**
NOT TO SCALE

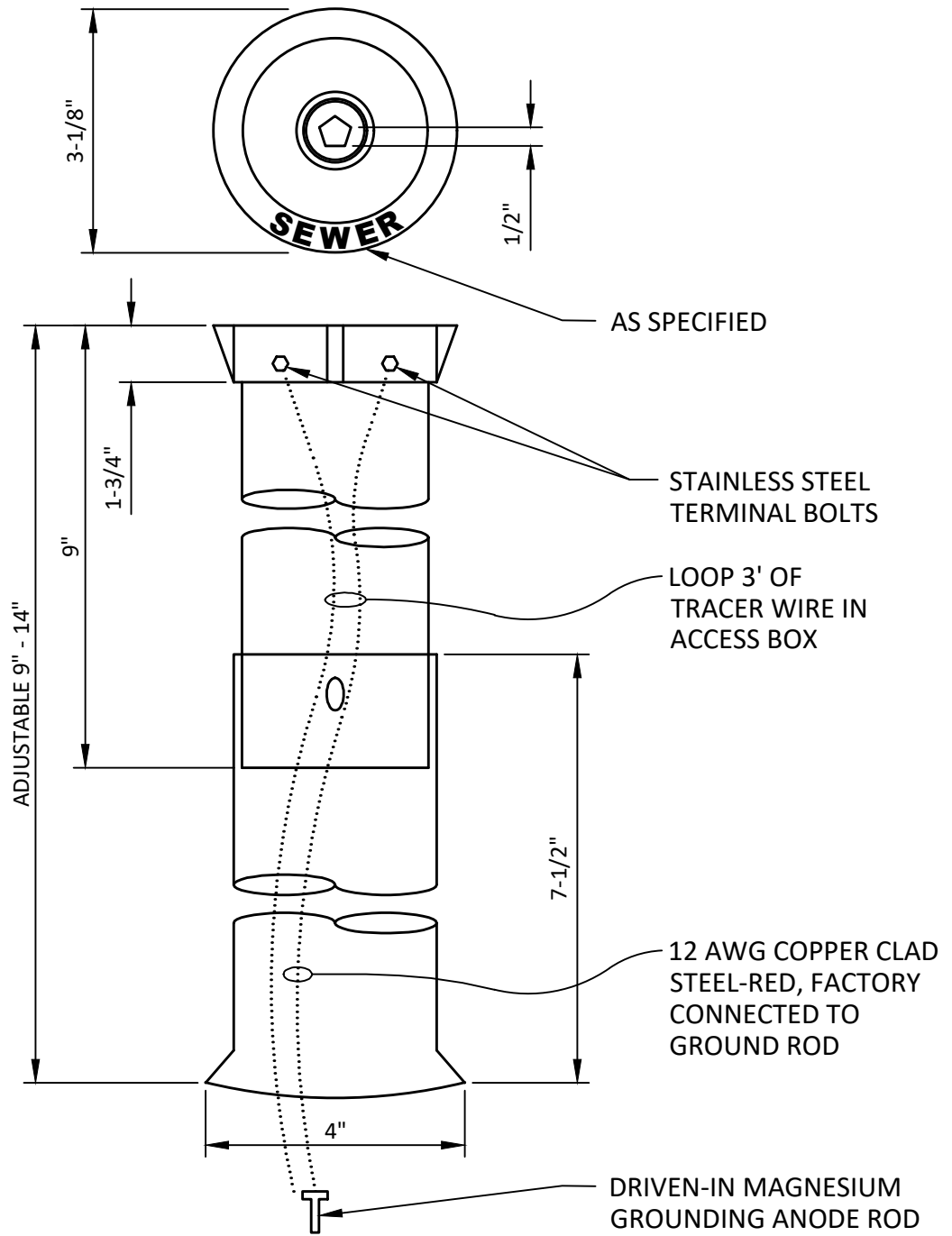

**ADJUSTABLE
TRACER WIRE ACCESS BOX**

NOT TO SCALE

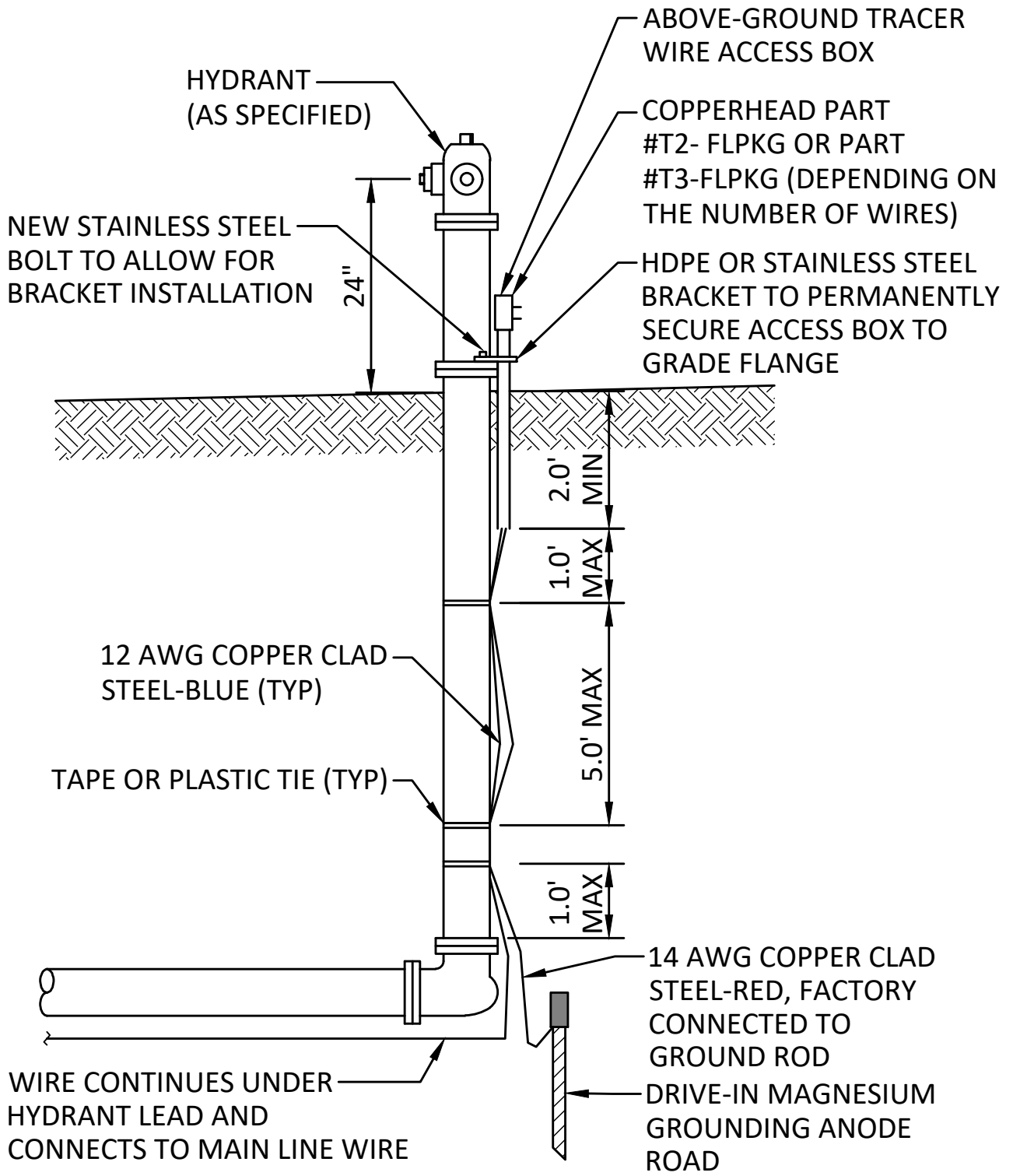

TRACER WIRE ACCESS AT HYDRANT

NOT TO SCALE

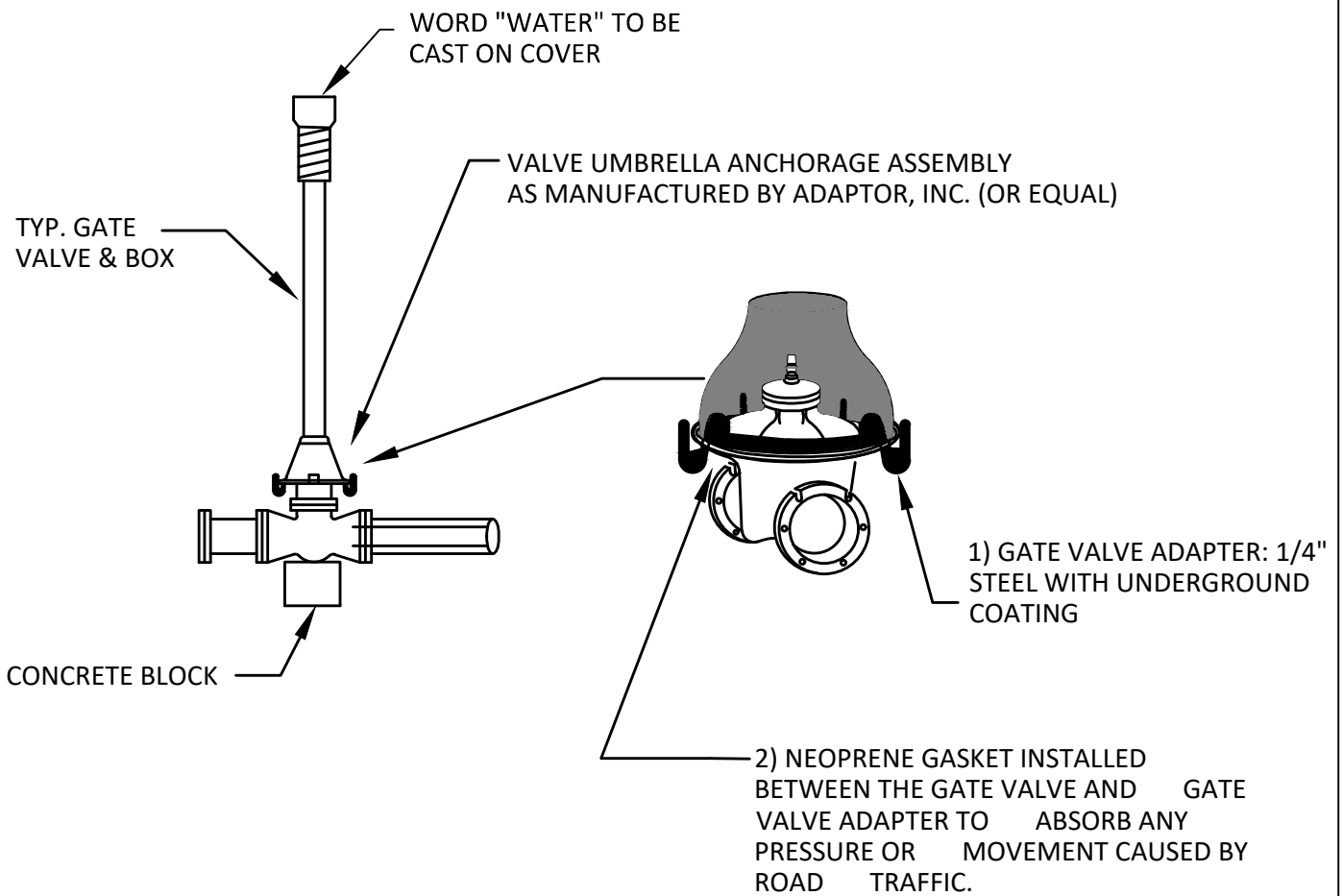

GATE VALVE ADAPTOR

NOT TO SCALE

NOTES:

1. VALVE BOX SHALL BE CENTERED ON OPERATING NUTS, STRAIGHT, FREE FROM DEBRIS, AND ALL SECTIONS UNBROKEN
2. VALVES IN EASEMENTS SHALL HAVE CHANNEL POST WITNESS MARKERS WITH REFLECTIVE "GV" SIGN
3. DEEP VALVES SHALL HAVE NUT EXTENSIONS INSTALLED TO ELEVATION TO ACCOMMODATE STANDARD 10' KEY.
4. COMPACTION WITH MECHANICAL TAMPER AROUND VALVE BOX SHALL BE PLACED AND COMPACTED WITH 2' LIFTS TO ACHIEVE 95% COMPACTION
5. GATE VALVES LOCATED WITHIN THE CONCRETE SIDEWALK SHALL INCLUDE A METAL SEPARATOR BETWEEN THE VALVE BOX AND THE CONCRETE

AMERICAN - 80 KENNEDY
 KEN-SEAL, CLOW 2832
 RESILIENT SEAT VALVE OR
 EQUAL, CONFORMING TO
 AWWA C-515 STANDARDS

VALVES LARGER THAN 12"
 SHALL BE BUTTERFLY VALVES

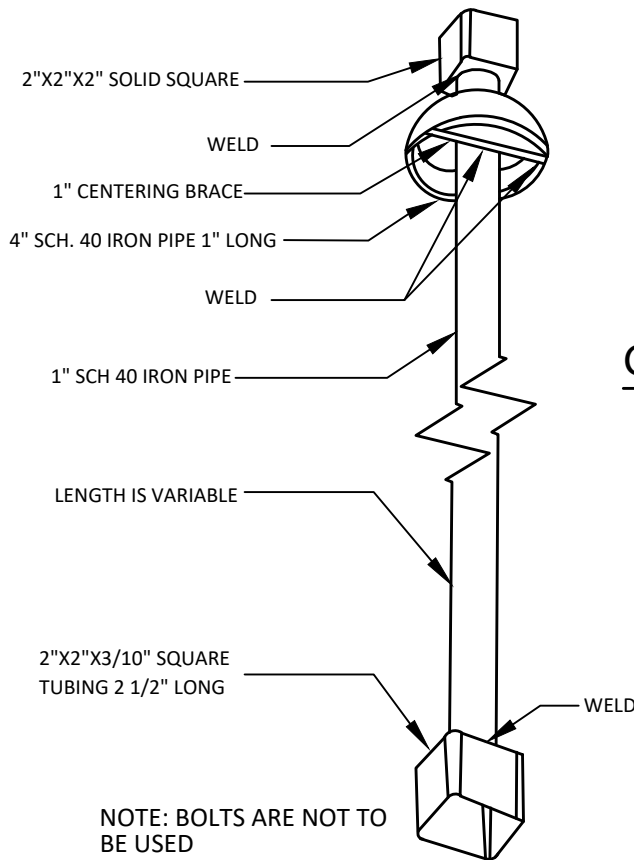

GATE VALVE EXTENSION STEM
 NOT TO SCALE

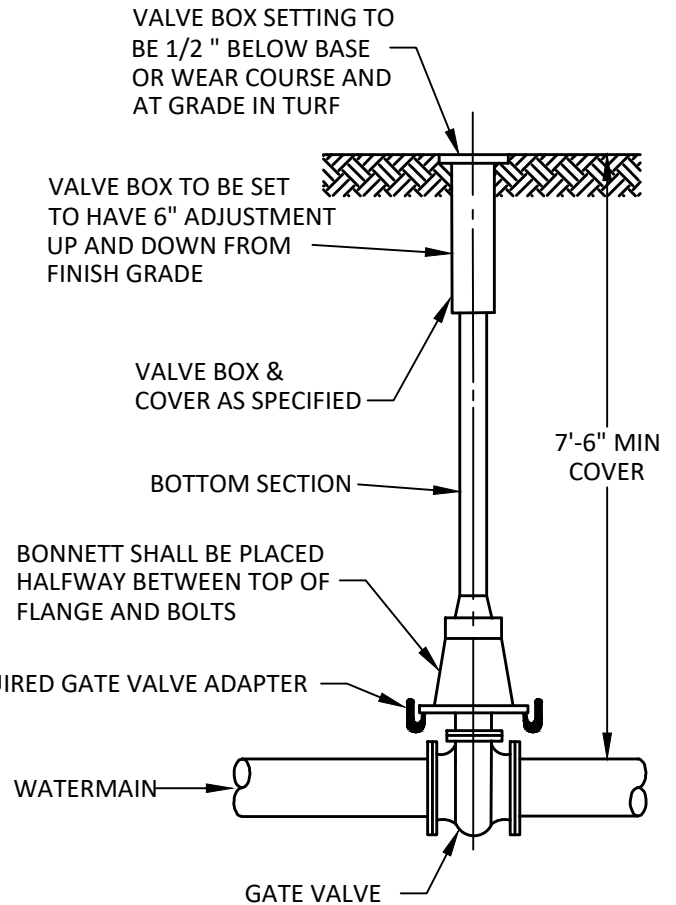

GATE VALVE BOX INSTALLATION
 NOT TO SCALE

AFTER FABRICATION, THE ENTIRE GATE VALVE EXTENSION STEM SHALL BE PAINTED WITH A SHOP APPLIED PRIMER AND EXTERIOR EPOXY PAINT

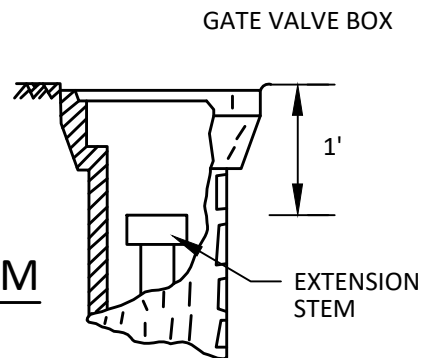

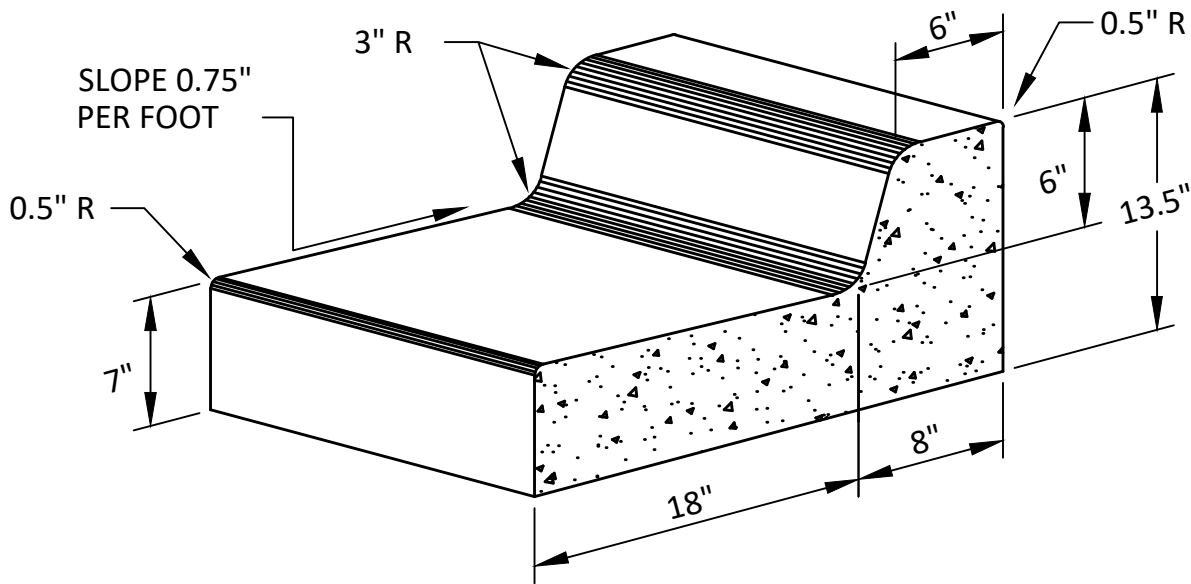

**CONCRETE CURB & GUTTER
DESIGN B618**

NOT TO SCALE

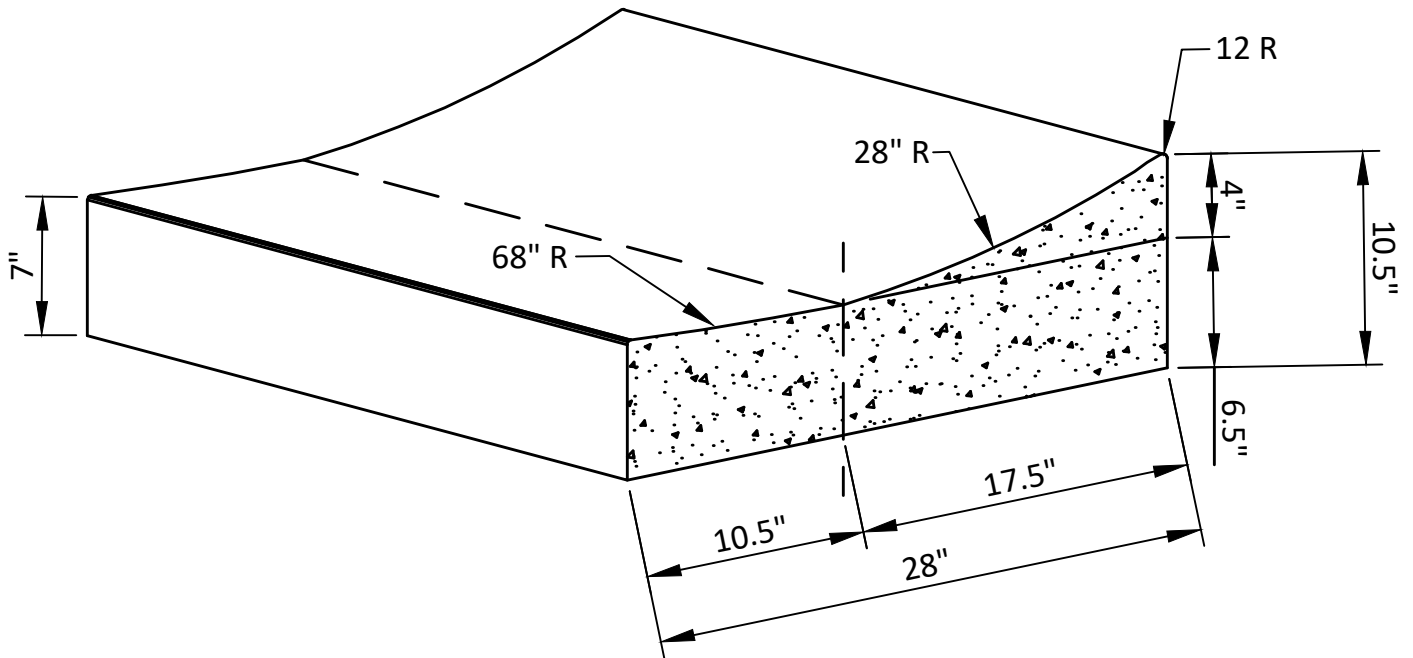

**SURMOUNTABLE
CURB & GUTTER**

NOT TO SCALE



CONCRETE
CURB & GUTTER



DATE:
02/2020

STD. DETAIL
7-000

NOTE:
 SURMOUNTABLE CURB & GUTTER TO BE FORMED INTO A
 B618 TYPE AT CATCHBASIN

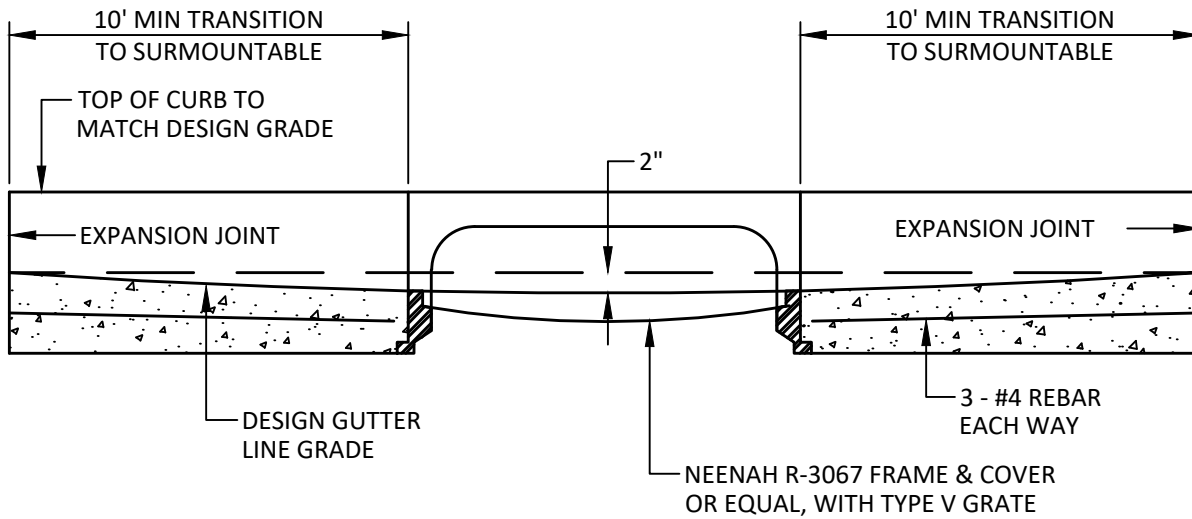
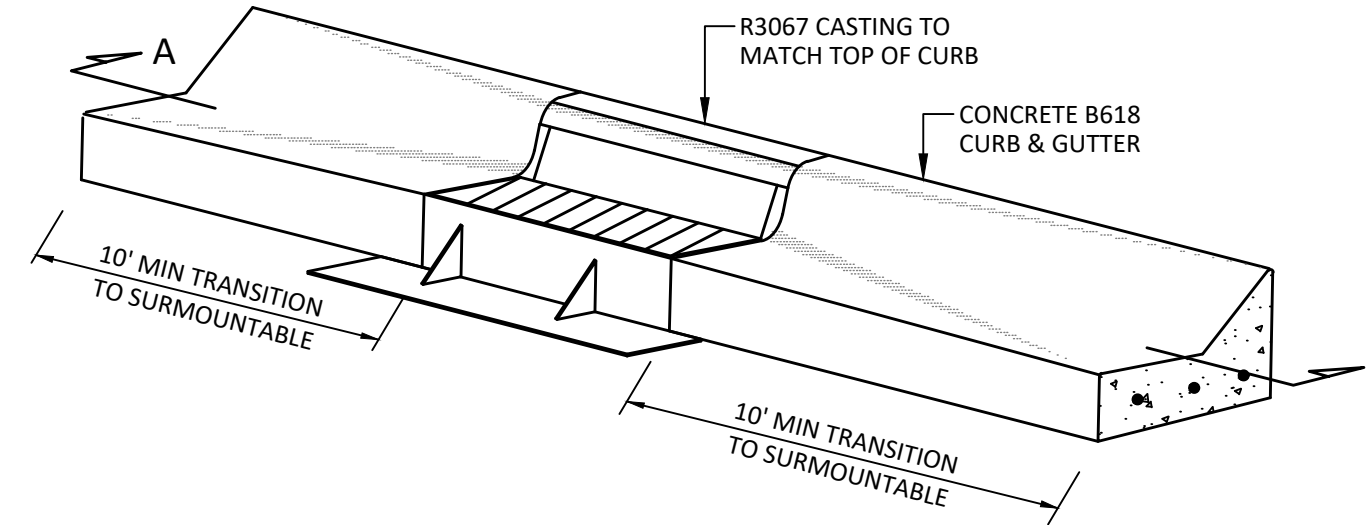

SECTION A-A

TRANSITION TO B618 CURB
AT CATCHBASIN
 NOT TO SCALE



TRANSITION TO
 B618 CURB AT
 CATCHBASIN



DATE:
 02/2020

STD. DETAIL
 7-001

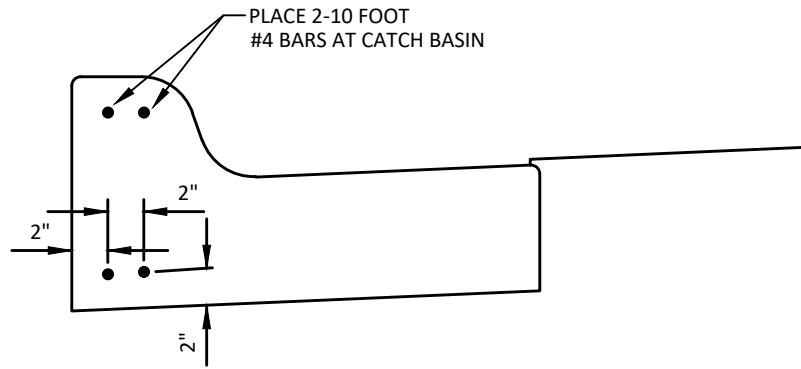

BXXX CONCRETE CURB & GUTTER
NOT TO SCALE

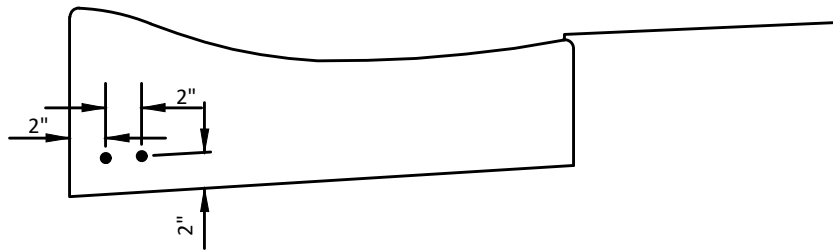

SURMOUNTABLE CONCRETE CURB & GUTTER
NOT TO SCALE

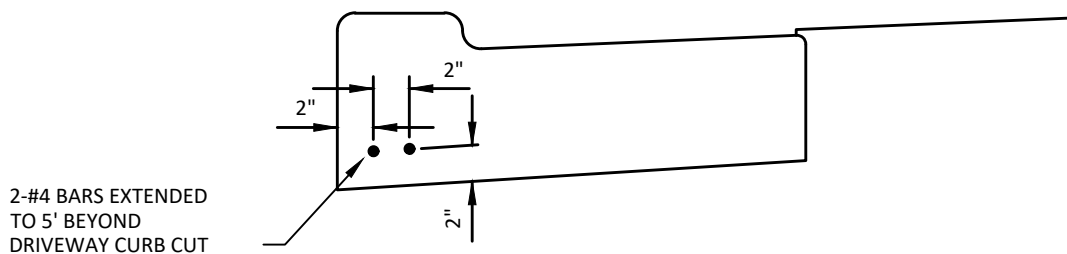

NOTE:
PLACE 2 - 20 FOOT # 4 BARS IN
THE LOWER PORTION OF THE CURB
AT ALL SERVICE TRENCH LOCATIONS

CONCRETE DRIVEWAY SECTION
NOT TO SCALE

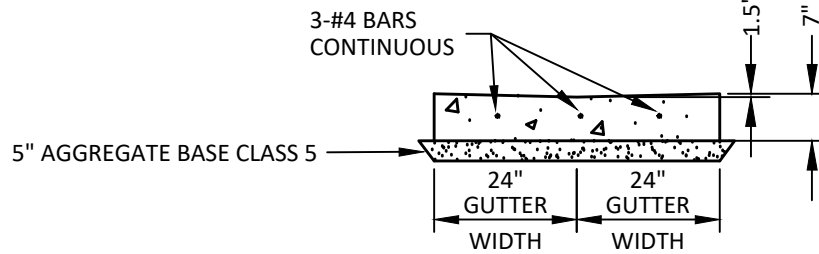
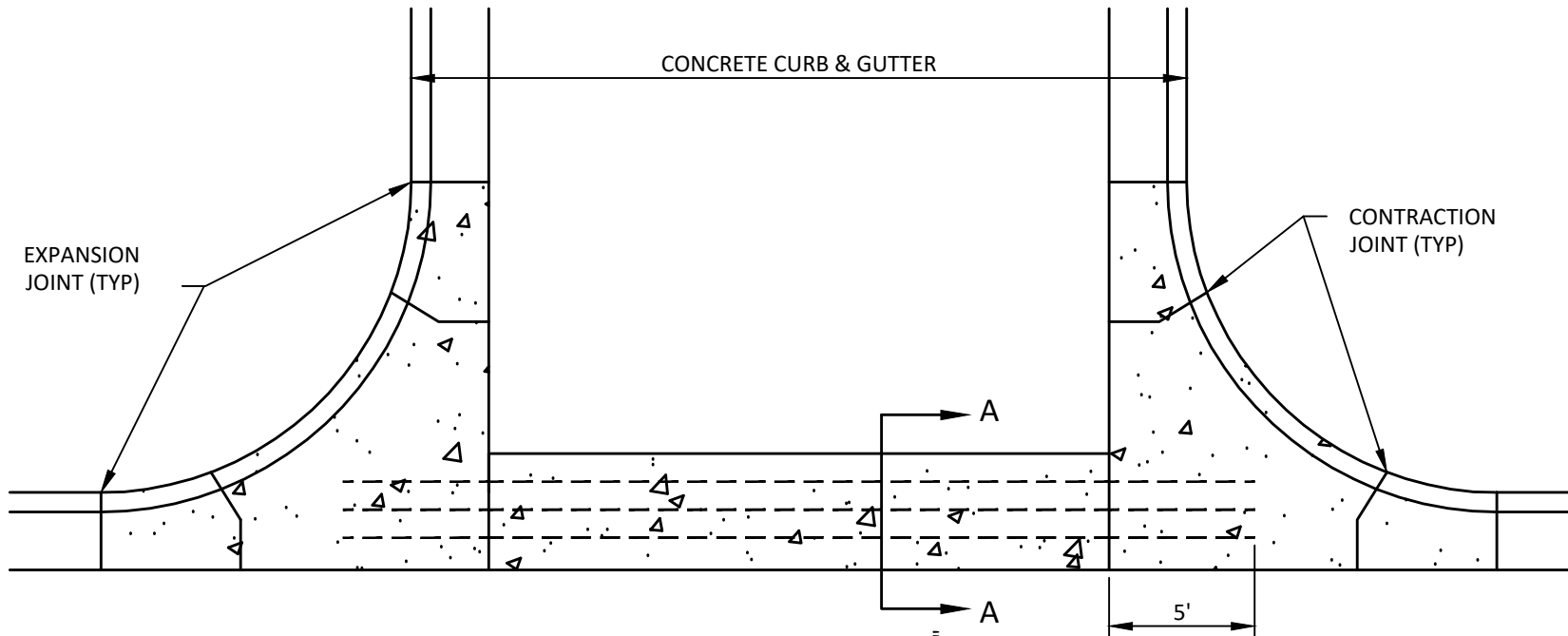

- NOTE:**
1. NO CONTRACTION JOINTS IN VALLEY GUTTER
 2. THE CONCRETE VALLEY GUTTER SHALL BE CONSTRUCTED ON 5" AGGREGATE BASE, CLASS 5

SECTION A
CONCRETE VALLEY GUTTER
 NOT TO SCALE



CONCRETE VALLEY GUTTER



DATE:
02/2020

STD. DETAIL
7-100

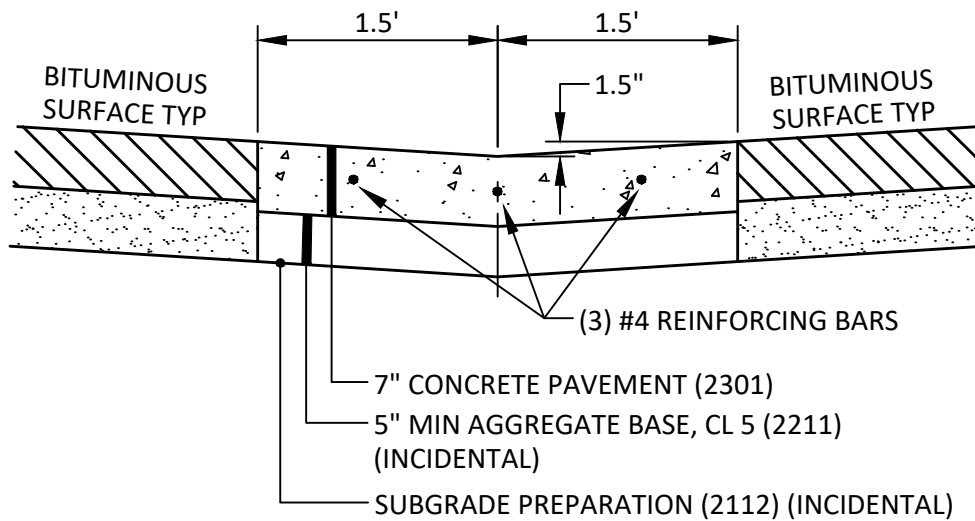

CONCRETE DRAINAGE PAN
NOT TO SCALE

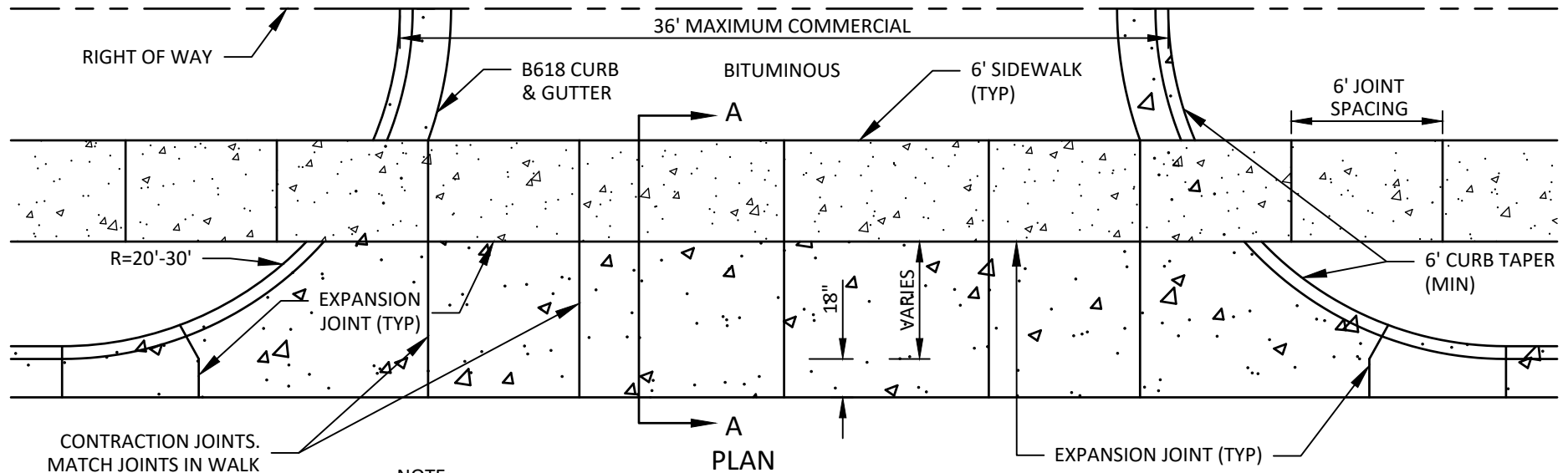
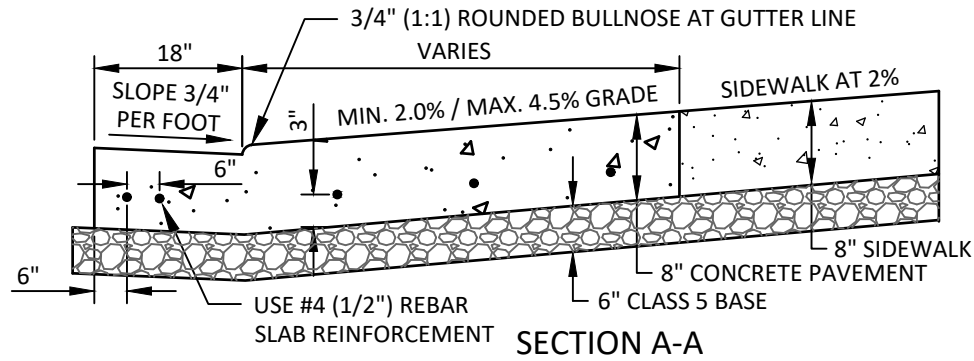

NOTE:

1. USE #4 (1/2") REBAR SLAB REINFORCEMENT IN R.O.W. PLACED @ 6" FROM EACH EDGE. REBAR TO BE 2' ON CENTER, BEING 6" ON CENTER IN THE GUTTER.
2. CONTRACTION JOINTS SHALL BE 1/3 THE DEPTH OF THE SLAB.
3. MAXIMUM PAVEMENT SLOPE ALLOWED WITHIN 30' OF THE STREET IS 4.5%.
4. AGGREGATE USED IN THE CONCRETE MIX SHALL BE GRANITE.
5. HIGHBACK CURB MUST BE POURED MONOLITHICALLY WITH DRIVEWAY, SURMOUNTABLE CURB MAY BE POURED SEPARATELY.

COMMERCIAL CONCRETE DRIVEWAY APRON

NOT TO SCALE



COMMERCIAL CONCRETE
DRIVEWAY APRON



DATE:
09/2021

STD. DETAIL
7-102

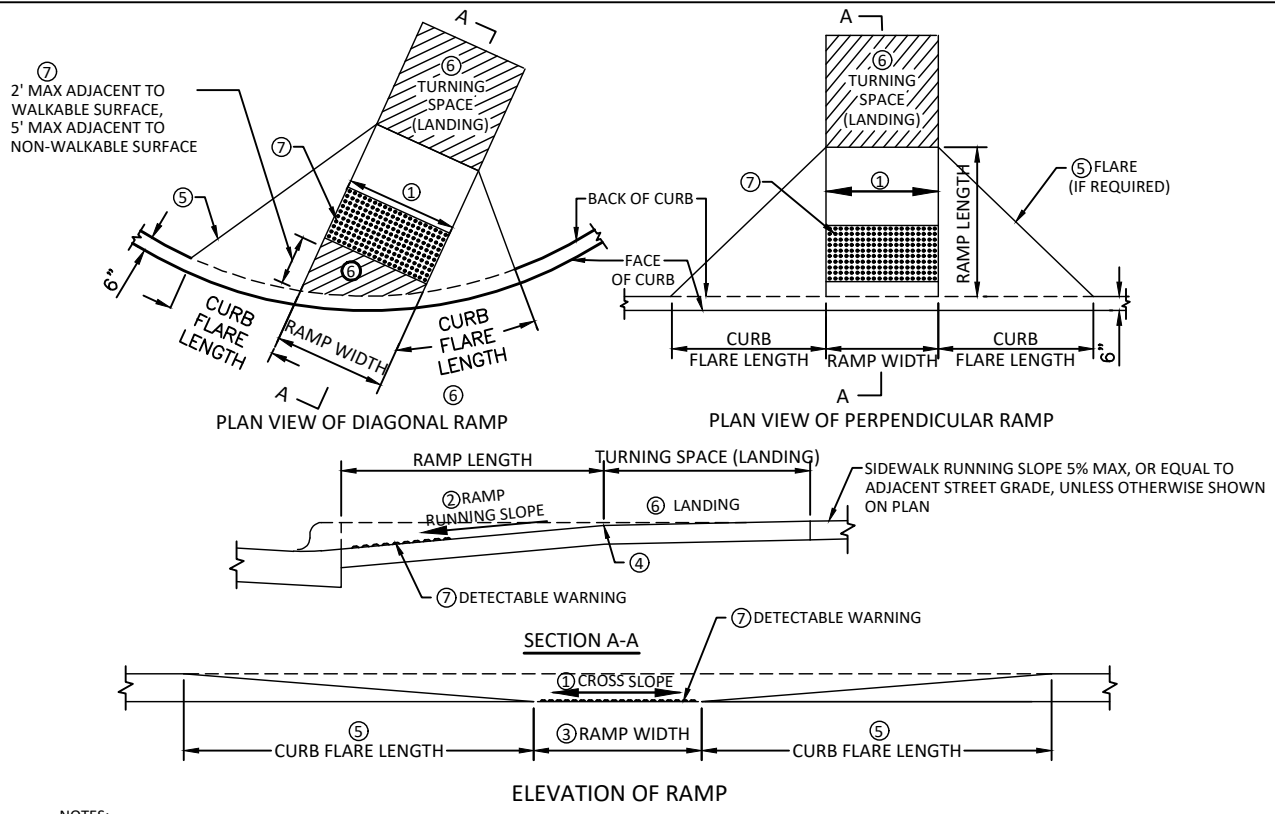

- NOTES:**
- ① **CROSS SLOPE:** THE MAXIMUM CROSS SLOPE IS 2.0% WITH A TARGET VALUE OF 1.5% EXCEPT FOR CROSSINGS THAT DO NOT HAVE FULL STOP OR YIELD CONTROL FOR VEHICULAR TRAFFIC THE CURB RAMP CROSS SLOPE MAY MATCH THE SLOPE OF THE CROSSING STREET.
 - ② **RUNNING SLOPE:** CURB RAMPS SHALL HAVE A TARGET RUNNING SLOPE OF 5.0% AND A MAXIMUM SLOPE OF 8.3%.
 - ③ **RAMP WIDTH:** THE MINIMUM WIDTH OF A CURB RAMP IS 4 FEET EXCLUDING CURBS AND FLARES. IF THE SIDEWALK FACILITY IS WIDER THAN 4 FEET, THE TARGET VALUE FOR THE CURB RAMP IS EQUAL TO THE WIDTH OF THE SIDEWALK.
 - ④ **GRADE BREAKS:** GRADE BREAKS AT THE TOP AND BOTTOM OF CURB RAMPS MUST BE PERPENDICULAR TO THE DIRECTION OF THE CURB RAMP RUN. GRADE BREAKS ARE NOT ALLOWED ON THE SURFACE OF CURB RAMP RUNS AND TURNING SPACES.
 - ⑥ **FLARED SIDES:** WHERE THE SURFACE ADJACENT TO THE SIDEWALK IS A HARD (I.E. WALKABLE) SURFACE, THE FLARES ALONG THE SIDES OF THE CURB RAMP SHALL BE CONSTRUCTED AT 10% OR FLATTER. WHERE THE SURFACE ADJACENT TO THE SIDEWALK IS UNPAVED (TURF OR OTHER), CONCRETE FLARES ARE NOT REQUIRED UNLESS SHOWN ON THE PLAN. IF CONCRETE FLARES ARE NOT REQUIRED, GRADED FLARES WITH A MAX SLOPE OF 1:6 MAY BE USED.
- TURNING SPACE (LANDINGS):**
- A. **PLACEMENT:** A TURNING SPACE IS REQUIRED AT THE TOP OF PERPENDICULAR CURB RAMPS WHEN THE RAMP RUNNING SLOPE EXCEEDS 5%, AT THE TOP OF ALL RAMPS WHERE A CHANGE IN DIRECTION FOR USERS IS ANTICIPATED, AND AT THE BOTTOM OF PARALLEL (SIDEWALK PARALLELING BACK OF CURB) CURB RAMPS.
 - ⑦ B. **SLOPE:** THE MAXIMUM SLOPE IN ANY DIRECTION IS 2.0% WITH A TARGET VALUE OF 1.5%. WHEN TURNING SPACES ARE AT THE BACK OF CURB, CROSS SLOPES MAY BE INCREASED TO MATCH ALLOWABLE VALUES IN THE PEDESTRIAN STREET CROSSING SECTION.
 - C. **SIZE:** THE TURNING SPACE SHALL BE A MINIMUM OF 4 FEET BY 4 FEET. WHERE THE TURNING SPACE IS ADJACENT TO A FIXED OBJECT OR CONSTRAINED ON ONE OR MORE SIDES, PROVIDE 5 FEET IN THE DIRECTION OF THE PEDESTRIAN STREET CROSSING.
- DETECTABLE WARNINGS:**
- A. THE DETECTABLE WARNING SHALL CONTRAST VISUALLY (LIGHT ON DARK OR DARK ON LIGHT) FROM THE SURROUNDING PAVED SURFACES.
 - B. **LOCATION:** DETECTABLE WARNINGS SHALL BE INSTALLED AT ALL PEDESTRIAN STREET CROSSINGS, PUBLIC PARKING LOT ACCESS POINTS, AT-GRADE RAIL CROSSINGS, AND COMMERCIAL/INDUSTRIAL DRIVEWAYS THAT HAVE YIELD CONTROL, STOP CONTROL, OR TRAFFIC SIGNALS. DETECTABLE WARNING SURFACES SHOULD ONLY BE PROVIDED AT CROSSINGS OF COMMERCIAL/INDUSTRIAL ENTRANCES NOT MEETING THE ABOVE CRITERIA WHEN SHOWN IN THE PLAN. RECTANGULAR DETECTABLE WARNINGS SHALL BE SETBACK 3" FROM THE BACK OF CURB. RADIAL DETECTABLE WARNING SHALL BE SETBACK 3" MIN. TO 6" MAX. FROM THE BACK OF CURB.
 - C. **SIZE:** DETECTABLE WARNING SURFACES SHALL EXTEND A MINIMUM OF 2 FEET IN THE DIRECTION OF PEDESTRIAN TRAVEL AND EXTEND THE FULL WIDTH OF THE CURB RAMP OR PEDESTRIAN ACCESS ROUTE.
 - ⑧ D. **DOME ORIENTATION:** ON CURB RAMPS, THE ROWS OF TRUNCATED DOMES SHOULD BE ALIGNED IN THE DIRECTION OF TRAVEL TOWARD THE CURB RAMP OPPOSITE THE STREET CROSSING ("DIRECTIONAL ALIGNMENT"). WHERE A DIRECTIONAL ALIGNMENT PRODUCES A GAP EQUAL TO OR GREATER THAN 2' OR 5' (SEE DETAIL ABOVE) BETWEEN THE TRUNCATED DOME AND THE NEAREST BACK OF CURB, THE DOMES SHALL BE ALIGNED ALONG THE BACK OF CURB AND RADIAL DOMES SHOULD BE CONSIDERED. DOMES MAY BE SETBACK UP TO 9" FROM THE BACK OF CURB WITH CORNERS SET 3" FROM BACK OF CURB. IF 9" SETBACK IS EXCEEDED USE RADIAL TRUNCATED DOMES.
 - ⑨ E. **PARALLEL CURB RAMPS:** ON PARALLEL CURB RAMPS, DETECTABLE WARNING SHALL BE PLACED ON THE TURNING SPACE 3" FROM THE BACK OF CURB.
 - ⑩
- CONTRACTOR SHALL NOTIFY THE ENGINEER IMMEDIATELY IF ANY OF THE ABOVE REQUIREMENTS CANNOT BE MET DUE TO SITE CONSTRAINTS.
- REFER TO MNDOT PEDESTRIAN CURB RAMP DETAILS, STANDARD PLAN S-297.250 (5 SHEETS) FOR ADDITIONAL DETAILS AND RAMP OPTIONS
- ALL PEDESTRIAN RAMPS SHALL BE CONSTRUCTED IN ACCORDANCE WITH MNDOT STANDARD PLANS S-297.250 (5 SHEETS) WITH LATEST REVISION. ANY VARIANCE FROM THE STANDARD PLANS AND THIS DETAIL SHALL BE RESOLVED IN FAVOR OF THE STANDARD PLAN

**PED RAMP, WITH TRUNCATED DOMES,
IN CURB RADIUS**



**PED RAMP WITH
TRUNCATED DOMES
IN CURB RADIUS**



DATE:
02/2020

STD. DETAIL
7-201

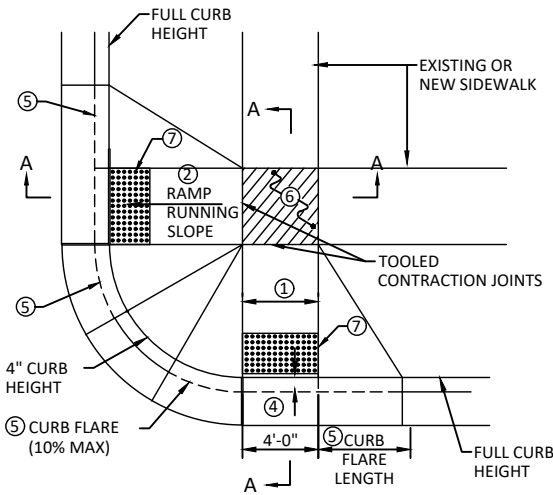

PLAN VIEW OF PERPENDICULAR STRAIGHT RAMP

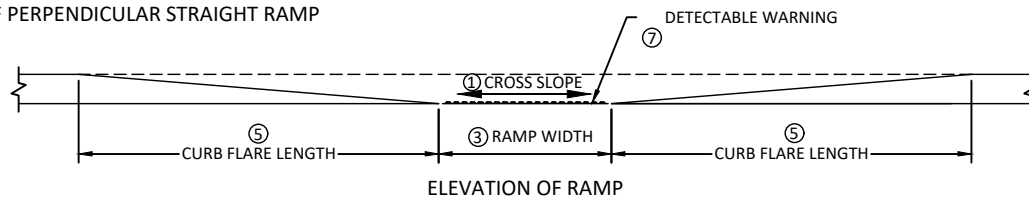
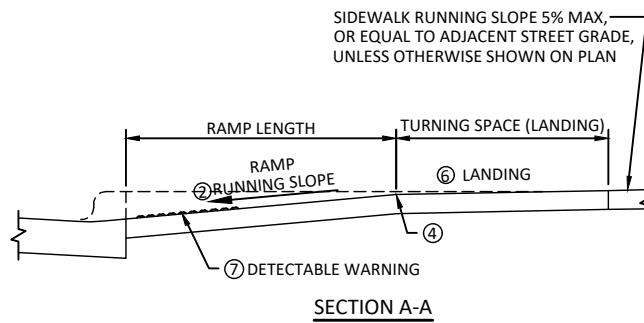

ELEVATION OF RAMP

NOTES:

- ① **CROSS SLOPE:**
THE MAXIMUM CROSS SLOPE IS 2.0% WITH A TARGET VALUE OF 1.5% EXCEPT FOR CROSSINGS THAT DO NOT HAVE FULL STOP OR YIELD CONTROL FOR VEHICULAR TRAFFIC THE CURB RAMP CROSS SLOPE MAY MATCH THE SLOPE OF THE CROSSING STREET.
- ② **RUNNING SLOPE:**
CURB RAMPS SHALL HAVE A TARGET RUNNING SLOPE OF 5.0% AND A MAXIMUM SLOPE OF 8.3%.
- ③ **RAMP WIDTH:**
THE MINIMUM WIDTH OF A CURB RAMP IS 4 FEET EXCLUDING CURBS AND FLARES. IF THE SIDEWALK FACILITY IS WIDER THAN 4 FEET, THE TARGET VALUE FOR THE CURB RAMP IS EQUAL TO THE WIDTH OF THE SIDEWALK.
- ④ **GRADE BREAKS:**
GRADE BREAKS AT THE TOP AND BOTTOM OF CURB RAMPS MUST BE PERPENDICULAR TO THE DIRECTION OF THE CURB RAMP RUN. GRADE BREAKS ARE NOT ALLOWED ON THE SURFACE OF CURB RAMP RUNS AND TURNING SPACES.
- ⑤ **FLARED SIDES:**
WHERE THE SURFACE ADJACENT TO THE SIDEWALK IS A HARD (I.E. WALKABLE) SURFACE, THE FLARES ALONG THE SIDES OF THE CURB RAMP SHALL BE CONSTRUCTED AT 10% OR FLATTER. WHERE THE SURFACE ADJACENT TO THE SIDEWALK IS UNPAVED (TURF OR OTHER), CONCRETE FLARES ARE NOT REQUIRED UNLESS SHOWN ON THE PLAN. IF CONCRETE FLARES ARE NOT REQUIRED, GRADED FLARES WITH A MAX SLOPE OF 1:6 MAY BE USED.
- ⑥ **TURNING SPACE (LANDINGS):**
 - A. PLACEMENT: A TURNING SPACE IS REQUIRED AT THE TOP OF PERPENDICULAR CURB RAMPS WHEN THE RAMP RUNNING SLOPE EXCEEDS 5%, AT THE TOP OF ALL RAMPS WHERE A CHANGE IN DIRECTION FOR USERS IS ANTICIPATED, AND AT THE BOTTOM OF PARALLEL (SIDEWALK PARALLELING BACK OF CURB) CURB RAMPS.
 - B. SLOPE: THE MAXIMUM SLOPE IN ANY DIRECTION IS 2.0% WITH A TARGET VALUE OF 1.5%. WHEN TURNING SPACES ARE AT THE BACK OF CURB, CROSS SLOPES MAY BE INCREASED TO MATCH ALLOWABLE VALUES IN THE PEDESTRIAN STREET CROSSING SECTION.
 - ⑦ C. SIZE: THE TURNING SPACE SHALL BE A MINIMUM OF 4 FEET BY 4 FEET. WHERE THE TURNING SPACE IS ADJACENT TO A FIXED OBJECT OR CONSTRAINED ON ONE OR MORE SIDES, PROVIDE 5 FEET IN THE DIRECTION OF THE PEDESTRIAN STREET CROSSING.
- ⑧ **DETECTABLE WARNINGS:**
 - A. THE DETECTABLE WARNING SHALL CONTRAST VISUALLY (LIGHT ON DARK OR DARK ON LIGHT) FROM THE SURROUNDING PAVED SURFACES.
 - B. LOCATION: DETECTABLE WARNINGS SHALL BE INSTALLED AT ALL PEDESTRIAN STREET CROSSINGS, PUBLIC PARKING LOT ACCESS POINTS, AT-GRADE RAIL CROSSINGS, AND COMMERCIAL/INDUSTRIAL DRIVEWAYS THAT HAVE YIELD CONTROL, STOP CONTROL, OR TRAFFIC SIGNALS. DETECTABLE WARNING SURFACES SHOULD ONLY BE PROVIDED AT CROSSINGS OF COMMERCIAL/INDUSTRIAL ENTRANCES NOT MEETING THE ABOVE CRITERIA WHEN SHOWN IN THE PLAN. RECTANGULAR DETECTABLE WARNINGS SHALL BE SETBACK 3" FROM THE BACK OF CURB. RADIAL DETECTABLE WARNINGS SHALL BE SETBACK 3" MIN. TO 6" MAX. FROM THE BACK OF CURB.
 - C. SIZE: DETECTABLE WARNING SURFACES SHALL EXTEND A MINIMUM OF 2 FEET IN THE DIRECTION OF PEDESTRIAN TRAVEL AND EXTEND THE FULL WIDTH OF THE CURB RAMP OR PEDESTRIAN ACCESS ROUTE.
 - ⑨ ⑩ D. DOME ORIENTATION: ON CURB RAMPS, THE ROWS OF TRUNCATED DOMES SHOULD BE ALIGNED IN THE DIRECTION OF TRAVEL TOWARD THE CURB RAMP OPPOSITE THE STREET CROSSING ("DIRECTIONAL ALIGNMENT"). WHERE A DIRECTIONAL ALIGNMENT PRODUCES A GAP EQUAL TO OR GREATER THAN 2' OR 5' (SEE DETAIL ABOVE) BETWEEN THE TRUNCATED DOME AND THE NEAREST BACK OF CURB, THE DOMES SHALL BE ALIGNED ALONG THE BACK OF CURB AND RADIAL DOMES SHOULD BE CONSIDERED. DOMES MAY BE SETBACK UP TO 9" FROM THE BACK OF CURB WITH CORNERS SET 3" FROM BACK OF CURB. IF 9" SETBACK IS EXCEEDED USE RADIAL TRUNCATED DOMES.

CONTRACTOR SHALL NOTIFY THE ENGINEER IMMEDIATELY IF ANY OF THE ABOVE REQUIREMENTS CANNOT BE MET DUE TO SITE CONSTRAINTS.

REFER TO MNDOT PEDESTRIAN CURB RAMP DETAILS, STANDARD PLAN S-297.250 (5 SHEETS) FOR ADDITIONAL DETAILS AND RAMP OPTIONS

ALL PEDESTRIAN RAMPS SHALL BE CONSTRUCTED IN ACCORDANCE WITH MNDOT STANDARD PLANS S-297.250 (5 SHEETS) WITH LATEST REVISION. ANY VARIANCE FROM THE STANDARD PLANS AND THIS DETAIL SHALL BE RESOLVED IN FAVOR OF THE STANDARD PLANS

NOT TO SCALE



PED RAMP WITH TRUNCATED DOMES IN STRAIGHT CURB SECTIONS



DATE:
02/2020

STD. DETAIL
7-202

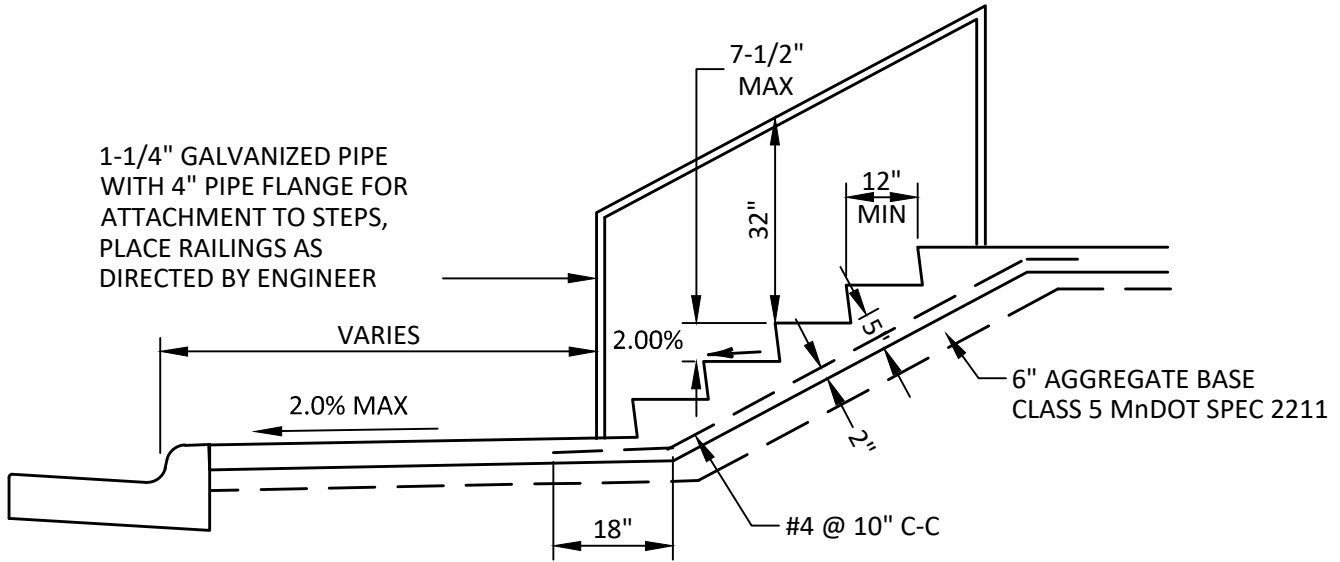

NOTE:
WIDTH TO MATCH EXISTING OR 4' MIN

CONCRETE STEPS
NOT TO SCALE

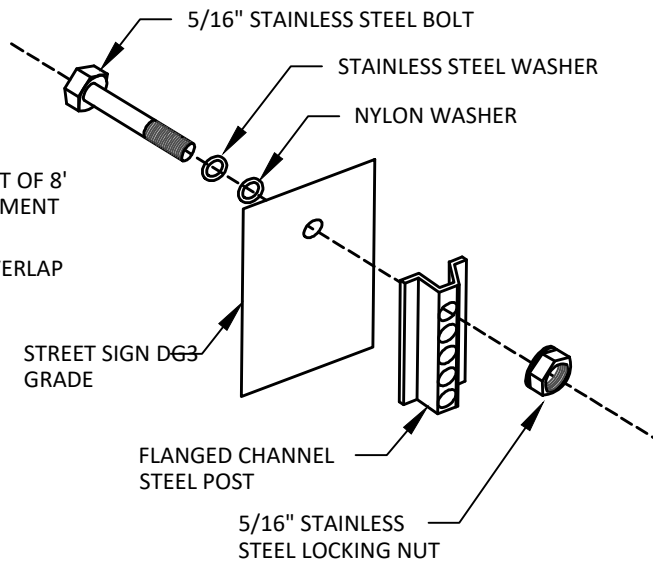
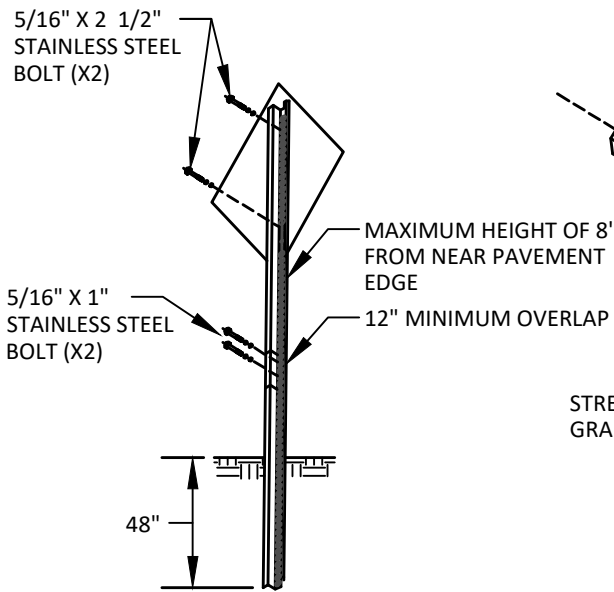

- 3M DIAMOND GRADE DG3 REFLECTIVE SHEETING.
- UPPER SIGN POST SHALL BE A 7' 2 LBS/FT GALVANIZED WHEN THE SIGN BEING INSTALLED IS 30" STOP SIGN OR SMALLER TRAFFIC SIGN.
- UPPER SIGN POST SHALL BE A 8' 2 LBS/FT GALVANIZED WHEN THE SIGN BEING INSTALLED IS 30" W-SERIES DIAMOND OR LARGER TRAFFIC SIGN.
- SIGN INSTALLED IN CONCRETE SHALL HAVE AN APPROVED BREAK-AWAY DEVICE. THIS DEVICE CAN BE PICK UP OR DELIVERED BY PUBLIC WORKS. CONTACT PUBLIC WORKS SIGN SHOP FOR DETAILS.
- WHEN TRAFFIC SIGNS ARE INSTALLED BETWEEN A SIDEWALK AND THE BACK OF CURB SPLIT THE DISTANCE.
- KEEP ALL TRAFFIC SIGNS 4' AWAY IN ALL DIRECTIONS FROM PEDESTRIAN RAMPS.

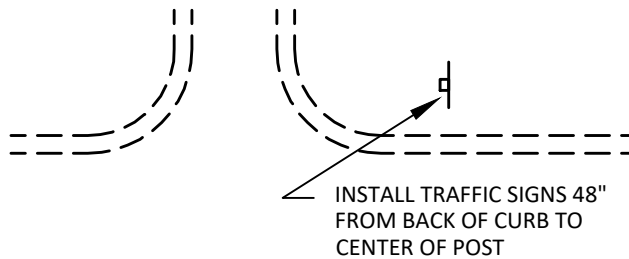

INSTALL TRAFFIC SIGNS 48" FROM BACK OF CURB TO CENTER OF POST

48" FROM BACK OF CURB TO CENTER OF POST OR 33" FROM BACK OF CURB TO NEAR EDGE OF SIGN WHICHEVER IS GREATER. THIS DISTANCE CAN BE LESS IN THE CASE OF A SIDEWALK RUNNING PARALLEL TO THE ROAD. IN THIS CASE THE SIGN POST SHOULD BE INSTALLED MIDWAY BETWEEN SIDEWALK EDGE AND BACK OF CURB .

NOTES:

- ALL REGULATORY AND STREET SIGNS MUST BE MAINTAINED THROUGHOUT CONSTRUCTION. TEMPORARY SIGNAGE MAY BE REQUIRED AND IS CONSIDERED INCIDENTAL.
- ALL IN-PLACE SIGNS NOT SHOWN IN PLANS SHALL BE MAINTAINED IN-PLACE THROUGHOUT CONSTRUCTION, UNLESS OTHERWISE DIRECTED BY THE ENGINEER.
- LOCATION OF ALL PROPOSED SIGNS ARE APPROXIMATE AND SHALL BE LOCATED BY THE ENGINEER IN THE FIELD PRIOR TO INSTALLATION.
- SIGN PANELS-REFLECTIVE SHEETING WILL BE DG3 MATERIAL.
- ALL TYPE C SIGN PANELS SHALL BE SUPPLIED AND INSTALLED BY THE CONTRACTOR. THE CONTRACTOR SHALL PROVIDE THE SIGN, SIGN POST, MOUNTING HARDWARE, SIGN AND LABOR FOR THE INSTALLATION OF ALL TYPE C SIGNS.
- A SIGN PLAN SHOWING SIGN COLORS, SIZES AND LETTERING MUST BE SUBMITTED TO THE CITY OF ALBERTVILLE ENGINEERING DEPARTMENT FOR REVIEW AND APPROVAL PRIOR TO SIGN INSTALLATION.

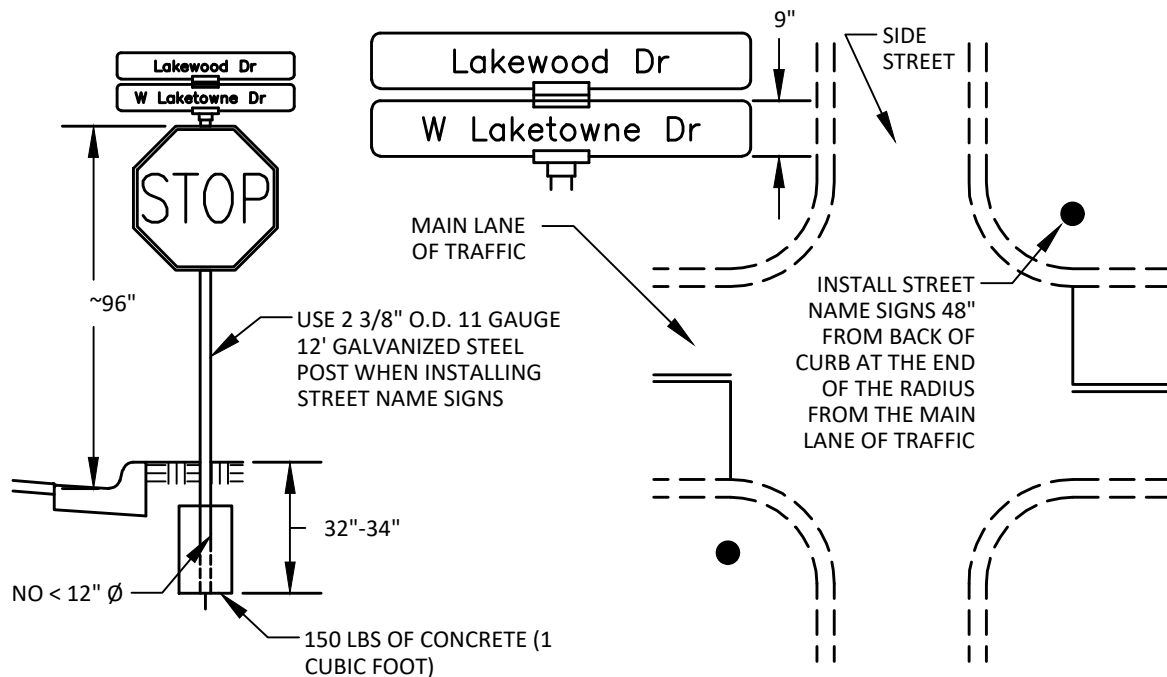

- BLADE SPECIFICATION -
- 9xL, S/F, DG3/080, WG, E450, E450, 63SP, UL
- LETTER SIZE - 6" UPPER CASE, 4" LOWER CASE
- 3M DIAMOND GRADE DG3 REFLECTIVE SHEETING
- WHITE ON MNDOT GREEN BACKGROUND FOR PUBLIC STREETS
- WHITE ON MNDOT BROWN BACKGROUND FOR PRIVATE STREETS
- STREET NAMES SHALL BE SPELLED COMPLETELY EXCEPT FOR SUFFIXES (Ave, La, Ct, Cir, Pkwy, St, Pl, Dr) WHICH MAY BE ABBREVIATED ON LONGER STREET NAMES
- FIRST LETTER OF EACH WORD TO BE "CAPITAL" LETTERS; REMAINING LETTERS OF EACH WORD TO BE LOWER CASE
- MAXIMUM OF 2 STREET NAME BLADES PER POLE. IF MORE STREET NAME BLADES ARE REQUIRED, CONTRACTOR WILL NEED TO INSTALL ANOTHER POLE ON OPPOSITE CORNER.
- ALWAYS INSTALL THE CROSS STREET NAME BLADE ON THE BOTTOM

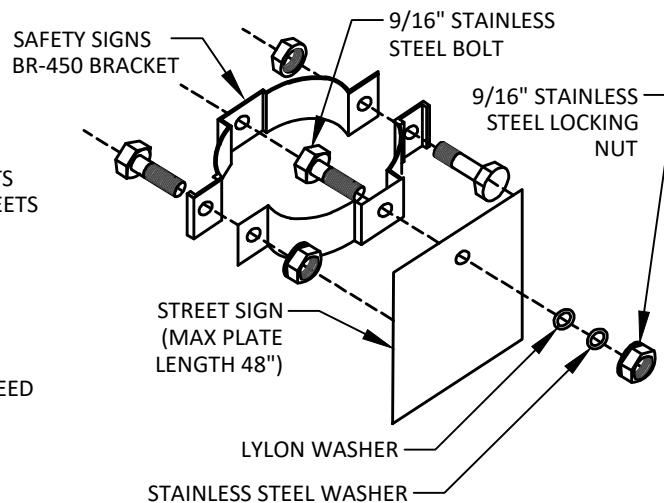

NOTES:

- ALL REGULATORY AND STREET SIGNS MUST BE MAINTAINED THROUGHOUT CONSTRUCTION. TEMPORARY SIGNAGE MAY BE REQUIRED AND IS CONSIDERED INCIDENTAL.
- ALL IN-PLACE SIGNS NOT SHOWN IN PLANS SHALL BE MAINTAINED IN-PLACE THROUGHOUT CONSTRUCTION, UNLESS OTHERWISE DIRECTED BY THE ENGINEER.
- LOCATION OF ALL PROPOSED SIGNS ARE APPROXIMATE AND SHALL BE LOCATED BY THE ENGINEER IN THE FIELD PRIOR TO INSTALLATION.
- SIGN PANELS-REFLECTIVE SHEETING WILL BE DG3 MATERIAL.
- ALL TYPE C SIGN PANELS SHALL BE SUPPLIED AND INSTALLED BY THE CONTRACTOR. THE CONTRACTOR SHALL PROVIDE THE SIGN, SIGN POST, MOUNTING HARDWARE, SIGN AND LABOR FOR THE INSTALLATION OF ALL TYPE C SIGNS.
- WHEN CONTRACTOR IS INSTALLING TYPE C SIGNS THEY MUST USE A BR-450 DOUBLE-SIDED SIGN BRACKET FROM SAFETY SIGNS (OR APPROVED EQUAL)
- A SIGN PLAN SHOWING SIGN COLORS, SIZES AND LETTERING MUST BE SUBMITTED TO THE CITY OF ALBERTVILLE ENGINEERING DEPARTMENT FOR REVIEW AND APPROVAL PRIOR TO SIGN INSTALLATION.



**STREET NAME BLADE
INSTALLATION
W/ TRAFFIC SIGN**



DATE:
02/2020

STD. DETAIL
8-101

5/16" X 2 1/2"
STAINLESS
STEEL BOLT (X2)

MAXIMUM HEIGHT
OF 8' FROM NEAR
PAVEMENT EDGE

3/8" STAINLESS
STEEL BOLT (X2)

BOTTOM OF SIGN TO
REST ON CONCRETE

8' 3# PER FOOT
CHANNEL POST

14" OF BREAK-AWAY TUBE
SHALL BE EXPOSED WITH
4" INSERTED INTO SLEEVE
(PROVIDED BY PUBLIC
WORKS)

2" X 2" X 18" SQUARE
TUBE SLEEVE (PROVIDED
BY PUBLIC WORKS)

- SIGN INSTALLED IN CONCRETE SHALL HAVE AN APPROVED BREAK-AWAY DEVICE. THIS DEVICE CAN BE PICKED UP OR DELIVERED BY PUBLIC WORKS. CONTACT PUBLIC WORKS SIGN SHOP FOR DETAILS.
- CREATE AN OVERSIZE CONCRETE WEDGE UNDER FLAT WORK TO PREVENT SLEEVE FROM BEING REMOVED.
- 2" X 2" BY 18" LONG SLEEVE SHALL BE INSTALLED WITH A 1/2" LIP PROTRUDING FROM TOP OF FLATWORK. CONCRETE FINISHING WORK FOR POST SHOULD PROMOTE DRAINAGE AWAY FROM SLEEVE.
- 1.5" X 1.5" BY 18" 12 GA. PRE-PUNCHED GALVANIZED SQUARE TUBE SHOULD BE INSERTED 4" INTO SLEEVE TO ENSURE PROPER BREAK-AWAY.

BREAK-AWAY/SLEEVE DETAIL

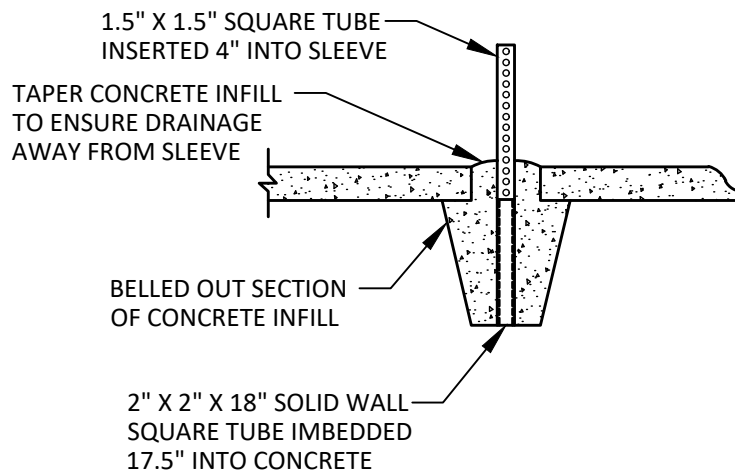

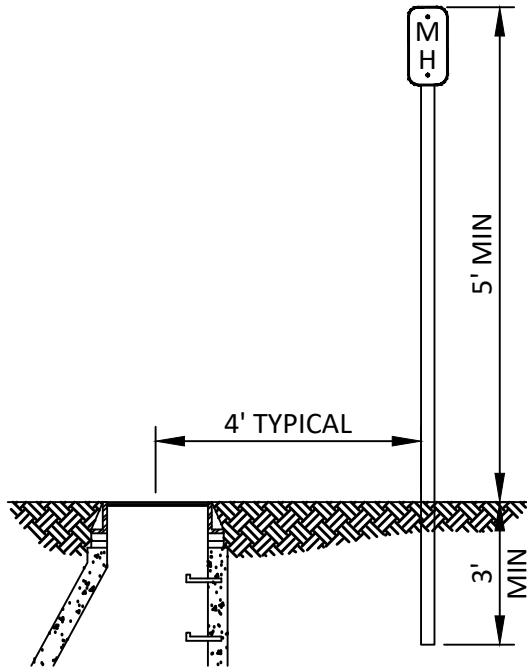

NOTES:

1. SIGNS TO BE A MIN OF 3"X6".
2. WHITE ON GREEN HIGH INTENSITY REFLECTORIZED BACK GROUND.
3. U-CHANNEL POST. MINIMUM 3LB/FT PAINTED GREEN.
4. WORDING SHALL BE:
M
H
5. SIGNS SHALL BE POSTED AT ALL MANHOLES IN UNIMPROVED AREAS OR AS SHOWN ON THE STRUCTURE SCHEDULE.

MANHOLE MARKER SIGN
NOT TO SCALE

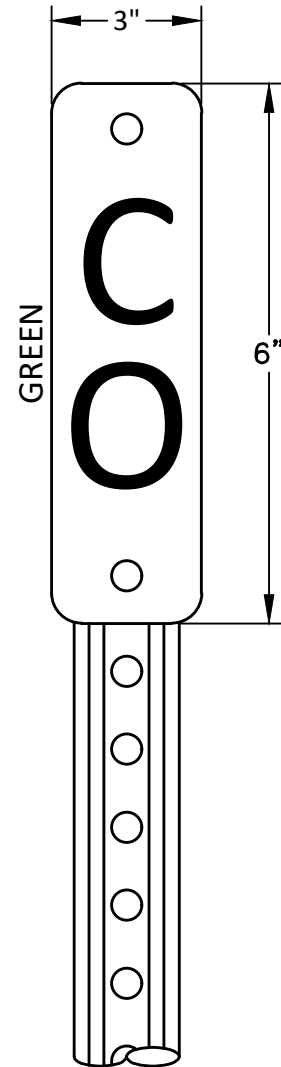
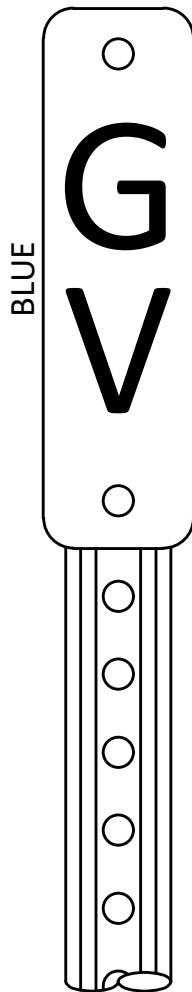
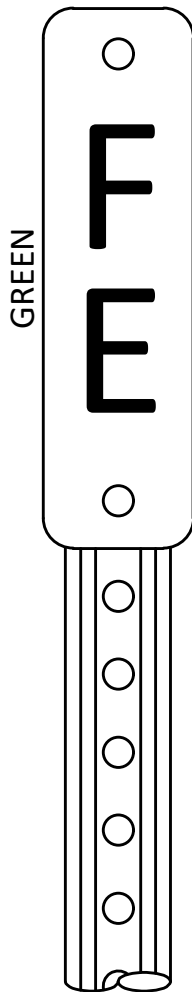

NOTES:

1. 0.063" THICK ALUMINUM SIGN. WHITE LETTERS ON VIP GRADE REFLECTORIZED BACKGROUND SHEETING.
2. U-CHANNEL POST, MINIMUM 3 LB/FT 6'-6" LONG, PAINTED GREEN. 2' BURY.
3. PLACED AS DIRECTED BY ENGINEER.
4. STRUCTURE MARKER SIGNS SHALL BE PLACED AT ALL STRUCTURES IN UNIMPROVED AREAS OR AS DIRECTED BY THE ENGINEER.

STRUCTURE MARKER SIGNS
NOT TO SCALE

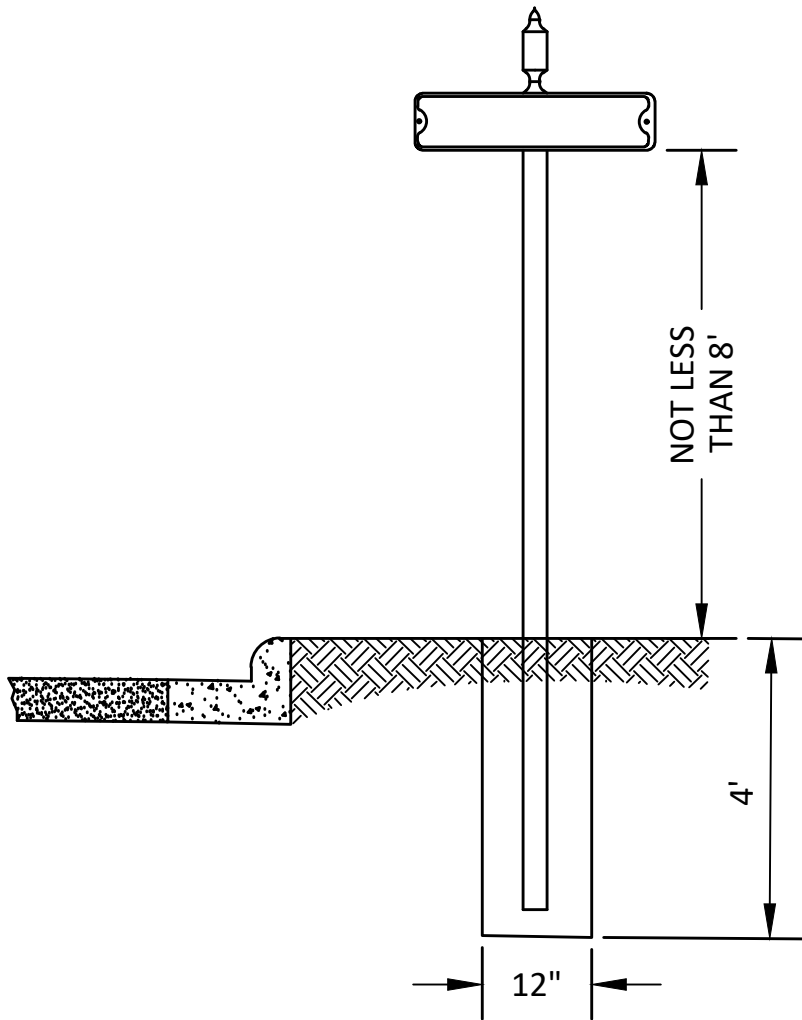

STREET NAME SIGN
NOT TO SCALE



NOTES:

SIGN POSTS SHALL BE CYLINDRICAL TUBE STEEL POSTS. THE POST SHALL BE 12' LONG, WITH 2-3/8" OD, AND SHALL MEET THE FOLLOWING: MATERIAL: GALVANIZED FINISH, ROLL FORMED FROM 12 GAUGE (.080 U.S.S. GAUGE) COLD ROLLED STEEL, GALVANIZED MATERIAL ASTM DES. A-446 GRADE A.

THE POST AND SIGN HARDWARE SHALL INCLUDE 1 E450 SINGLE BRACKET AND 1 E450 4-WAY BRACKET.

IT SHALL HAVE A 5/8" SQUARE CENTER ROD WELDED ON TO THE TUBULAR POLE CAP AND ACCOMMODATE A ORNAMENTAL NUT ON THE TOP OF THE ROD.

STREET SIGNS SHALL BE A 9" ALUMINUM .080 GAUGE PLATE WITH INITIAL 6" UPPERCASE WHITE LETTERS, 4.5" LOWER CASE LETTERS, NUMBERS, BORDER, AND MARKINGS, SERIES C LETTERS ON A GREEN BACKGROUND. THE REFLECTIVITY OF THE SIGN SHALL BE 3M VIP GRADE.

SIGNS AND INSTALLATION OF SIGNS SHALL BE IN ACCORDANCE WITH THE LATEST EDITION OF THE "MINNESOTA MANUAL OF UNIFORM TRAFFIC CONTROL DEVICES"

SIGN BASE MATERIAL SHALL BE ALUMINUM.

SIGN POST SHALL BE EMBEDDED IN 12" DIAMETER CONCRETE FOOTING TO A DEPTH OF 4-FEET. EARTH SHALL BE TAMPED AROUND CONCRETE ENCASEMENT.

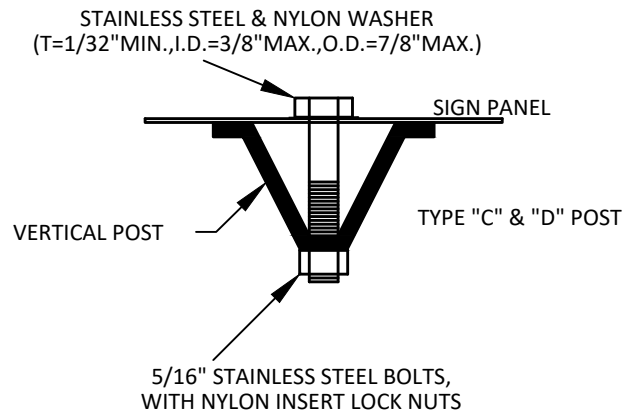
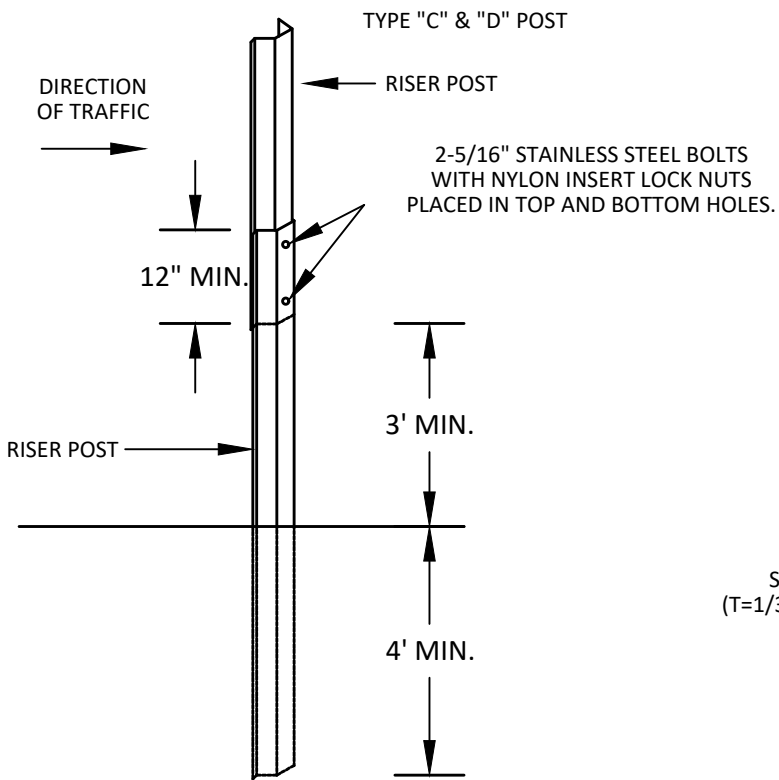

NOTES:

1. USE 3# GREEN STUB POSTS. DRIVEN STUB POSTS SHALL BE AT LEAST 8' LONG.
2. MOUNTING (PUNCHING CODE) FOR TYPE "C" SIGN PANELS SHALL BE INDICATED IN THE STANDARD SIGNS MANUAL UNLESS OTHERWISE SPECIFIED.
3. USE 2.0# GREEN RISER POSTS AT LEAST 7' LONG.
4. USE STAINLESS STEEL BOLTS, WASHERS AND NYLON INSERT LOCK NUTS AS SHOWN FOR ALL GROUND MOUNTED SIGNS.
5. STAINLESS STEEL WASHER WITH SAME DIMENSIONS SHALL BE PROVIDED BETWEEN ALL NYLON WASHERS AND BOLT HEADS.
6. ALL SIGNS LOCATED IN CONCRETE MEDIANS SHALL HAVE AN ADDITIONAL BREAKAWAY SYSTEM APPROVED BY THE CITY ENGINEER PRIOR TO CONSTRUCTION.

STREET SIGN POST INSTALLATION
NOT TO SCALE









STREET SIGN
POST INSTALLATION





DATE:
02/2020

STD. DETAIL
8-115

FURNISH AND INSTALL NEW SIGNS

SIGN NUMBER	SIGN	COLOR & SIZE	DESCRIPTION
*R1-1		30"X30" WHITE ON RED	ALUMINUM STOP SIGN
R2-1		24"X30" BLACK ON WHITE	ALUMINUM SPEED LIMIT SIGN
W11-X5		30"X30" BLACK ON YELLOW	ALUMINUM WATCH FOR CHILDREN SIGN
SPECIAL		18"X24" RED ON WHITE	ALUMINUM NO PARKING SIGN
W11-1		10"X18" BLACK ON YELLOW	ALUMINUM BICYCLE CROSSING SIGN
R5-3		24"X24" BLACK ON YELLOW	ALUMINUM NO MOTOR VEHICLES SIGN

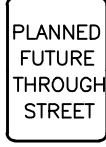
SIGN NUMBER	SIGN	COLOR & SIZE	DESCRIPTION
W16-7		24"X18" BLACK ON YELLOW	ALUMINUM DIAGONAL ARROW SIGN
SPECIAL		18"X24" BLACK ON WHITE	ALUMINUM DOGS MUST BE LEASHED SIGN
SPECIAL		18"X24" BLACK ON WHITE	ALUMINUM PARK CLOSED SIGN
SPECIAL		18"X24" BLACK ON WHITE	ALUMINUM PARK CLOSED SIGN

NOTES:

1. SIGNS AND INSTALLATION OF SIGNS SHALL BE IN ACCORDANCE WITH MnDOT SPECIFICATION 3352 AND THE LATEST EDITION OF THE "MINNESOTA MANUAL ON UNIFORM TRAFFIC CONTROL DEVICES."
2. ALUMINUM SHALL MEET THE REQUIREMENTS OF ASTM B 209M FOR ALLOY 5052-H38 OR ALLOY 6061-T6
3. REFLECTIVE SHEETING SHALL BE HIGH PERFORMANCE (D63) ON THE APPROVED MnDOT PRODUCTS LIST.

STREET SIGNS
NOT TO SCALE



STREET SIGNS



DATE:
02/2020

STD. DETAIL
8-116

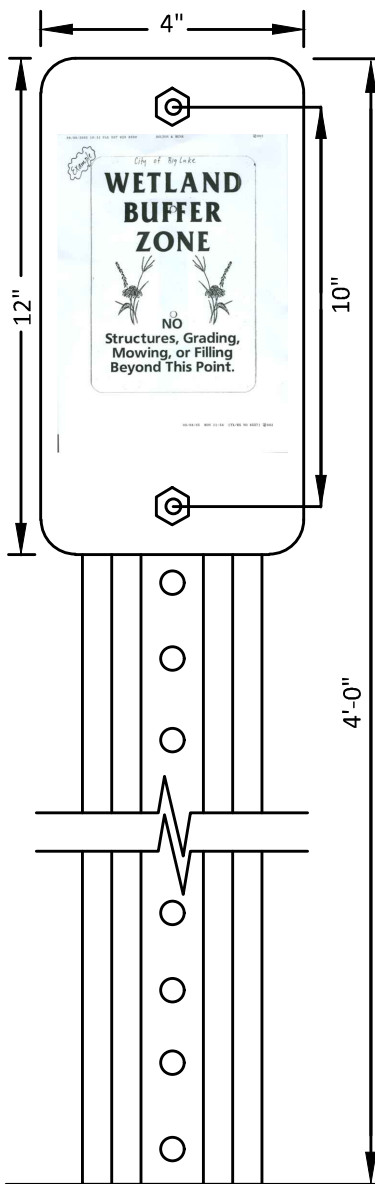

SIGN POST MUST BE $\pm 1/2$ " OF PLUMB WHEN IT IS SET

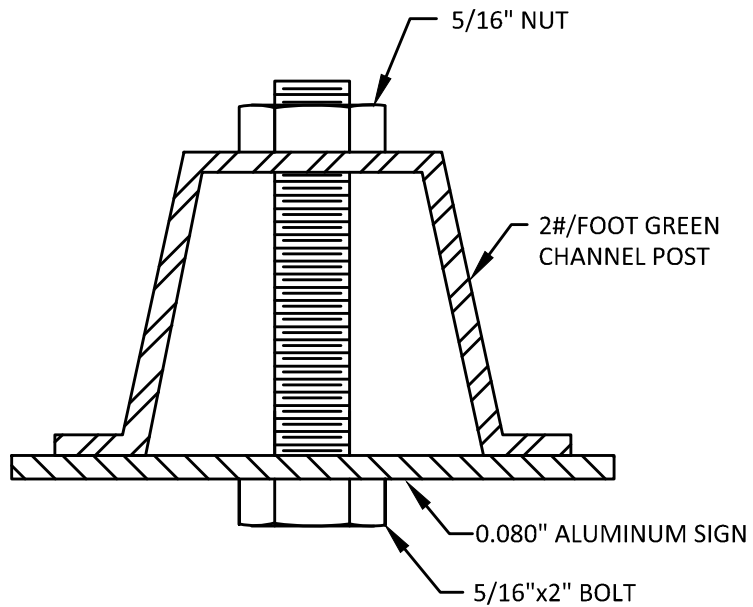

TYPICAL SECTION

NOTES:

1. MATERIALS TO BE SUPPLIED BY THE DEVELOPER/CONTRACTOR INCLUDE THE FOLLOWING:
 - (2) 4"x12"x0.080" ALUMINUM WETLAND BUFFER SIGNS
 - (2) 5/16"x2" CAD PLATED BOLTS
 - (4) 5/16" CAD PLATED NUTS
 - (1) 7' (2#/FOOT) GREEN CHANNEL POST
2. EACH BUFFER MARKER SHALL HAVE ONE SIGN FACING PRIVATE PROPERTY.
3. SIGNS TO BE INSTALLED BY THE DEVELOPER PER THE DRAWING SHOWN AT THE LEFT.
4. AS A GENERAL RULE, WETLAND BUFFER SIGNS SHOULD BE PLACED AT EVERY OTHER LOT CORNER. HOWEVER, AT NO TIME SHOULD THERE BE MORE THAN 200' BETWEEN SIGNS IN UNFORESTED AREAS AND 150' IN FORESTED AREAS.
5. SIGN PANELS SHALL CONSIST OF BROWN BACKGROUND WITH WHITE LETTERING.

WETLAND BUFFER ZONE SIGN INSTALLATION
NOT TO SCALE

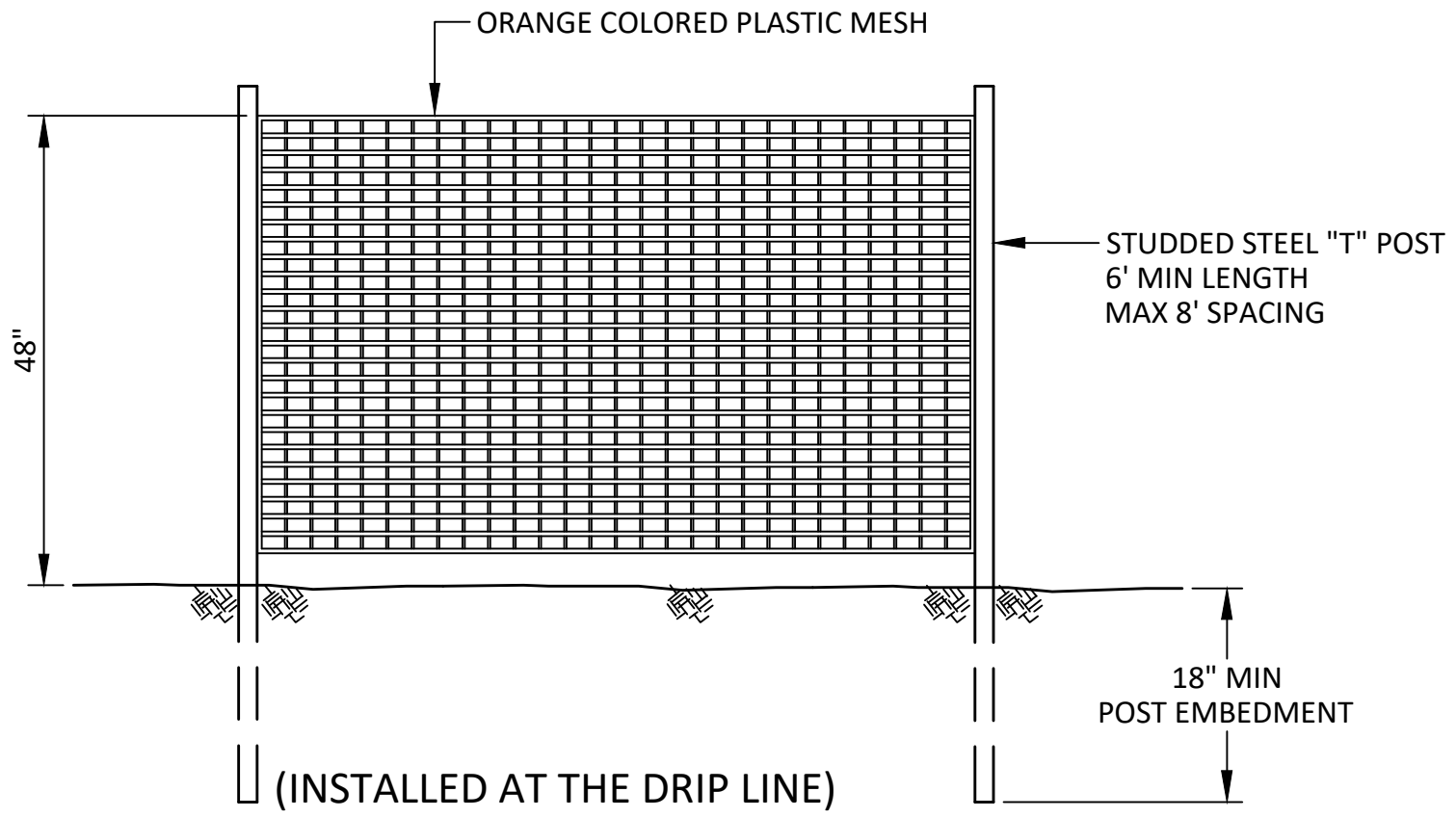

TREE PRESERVATION FENCE
NOT TO SCALE

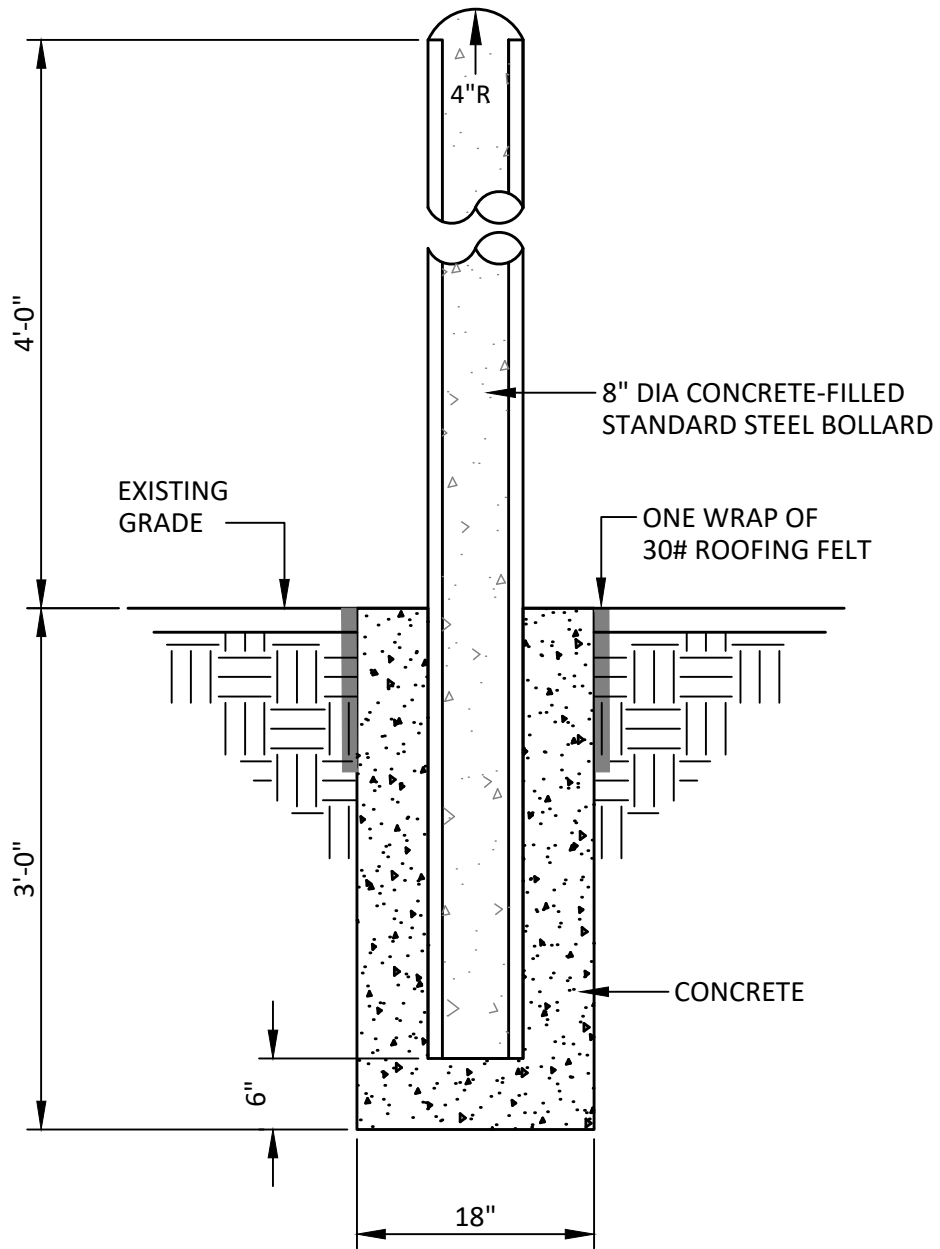

BOLLARD GUARD POST

NOT TO SCALE

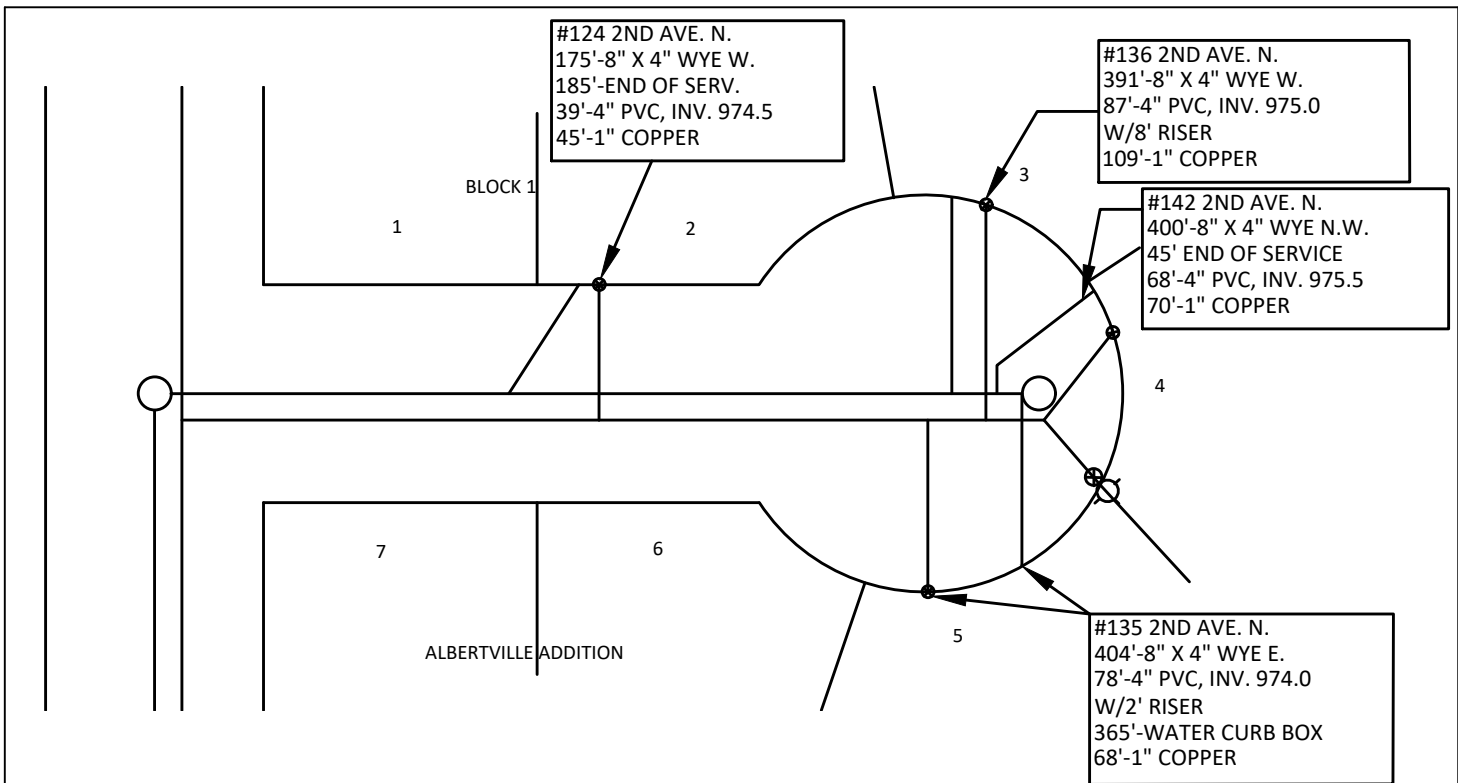

INFORMATION NEEDED TO COMPLETE CITY RECORD DRAWINGS

1. ADDRESS, IF AVAILABLE, OR LOT AND BLOCK NO. AND NAME OF ADDITION.
2. DISTANCE TO WYE FROM NEAREST DOWNSTREAM MANHOLE.
3. DISTANCE TO END OF SERVICE FROM NEAREST DOWNSTREAM MANHOLE (IF END OF SERVICE IS SKEWED MORE THAN 3' FROM THE WYE).
4. DISTANCE FROM NEAREST DOWNSTREAM MANHOLE TO WATER SERVICE CURB BOX (IF WATER SERVICES ARE IN THE SAME TRENCH WITH SEWER SERVICES, A NOTE INDICATING THAT SHOULD BE USED).
5. SIZE AND TYPE OF WYE.
6. SIZE AND TYPE OF SERVICE (SEWER OR WATER).
7. DIRECTION OF SERVICE.
8. LENGTH OF SERVICE (SEWER OR WATER).
9. INVERT ELEVATION AT END OF SEWER SERVICE.
10. RISER LENGTH
11. IF SERVICES IN CUL-DE-SACS ARE TO THE CENTER OF THE LOTS, A NOTE INDICATING THAT SHOULD BE USED. THIS COULD TAKE THE PLACE OF AN END OF SERVICE STATION.
12. WATER SERVICES ARE IN THE SAME TRENCH WITHIN 3' UPSTREAM OF SEWER SERVICES UNLESS OTHERWISE INDICATED.
13. TABLE WITH GPS COORDINATES OF ALL CURB STOPS, SANITARY SEWER SERVICE WYES AND LOCATION OF THE SANITARY SEWER SERVICE AT THE EASEMENT LINE. COORDINATES SHALL BE ON THE MN COORDINATE SYSTEM, SOUTHERN ZONE, NAD 83, 1986 (NON HARN VALVES).



**SEWER & WATER
SERVICE
RECORD DRAWING**



DATE:
02/2020

STD. DETAIL
9-600